

SONIC CATAMARAN DRIVE, Mk. 2

Owners Handbook

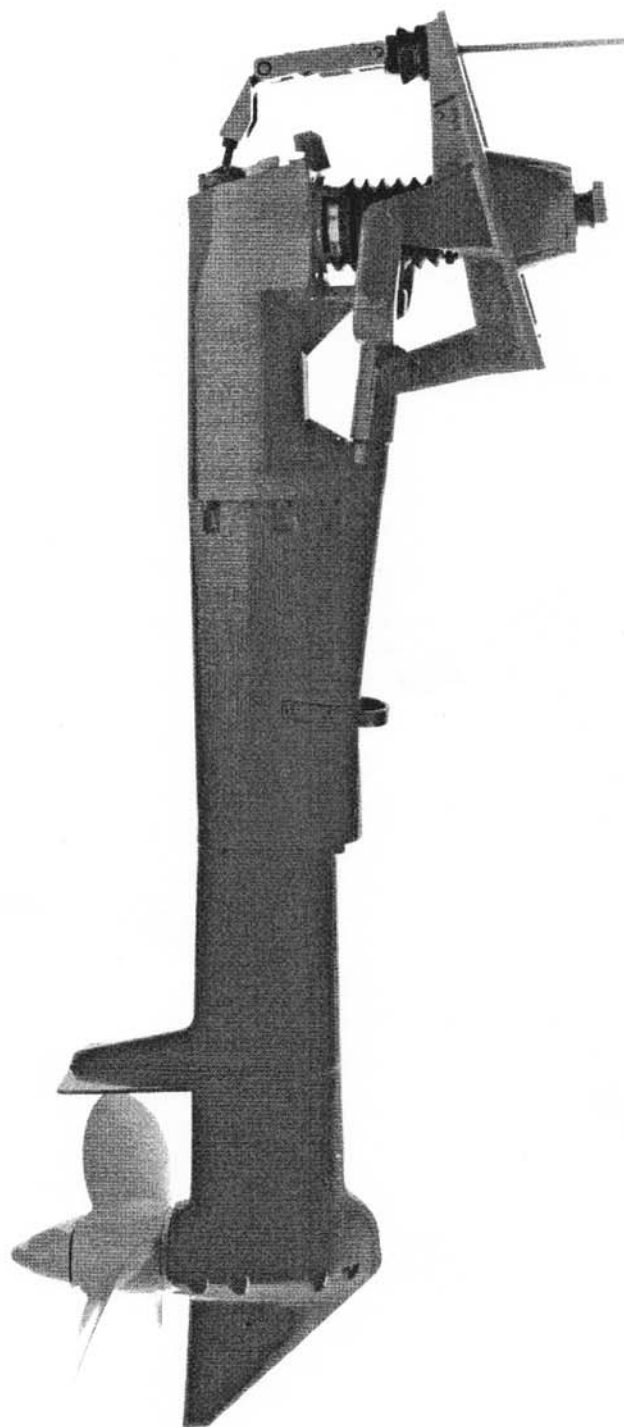

SILLETTE-SONIC LTD

SONIC CATAMARAN DRIVE MKII

CONTENTS

1 FOREWORD AND TECHNICAL SPECIFICATION	PAGE	1
2 INSTALLATION DETAILS	PAGE	2
3 NOTES REGARDING REMOVAL OF DRAIN PLUG	PAGE	6A
4 HINTS FOR THE HELMSMAN	PAGE	7
5 SERVICING	PAGE	9
6 GENERAL INFORMATION + ASSEMBLY DRAWING	PAGE	13
7 HYRAULIC LIFT SUPPLEMENT	PAGE	18
8 PARTS LIST AND ACCESSORIES	PAGE	22
9 BEARING SYSTEM INTRODUCED 2002 – ASSEMBLY DRAWING	PAGE	24
10 INSTRUCTIONS FOR REMOVAL AND REPLACEMENT OF STEERING YOKE ITEM 35	PAGE	24A
11 MANUAL REVERSE LOCK SUPPLEMENT	PAGE	25
12 SINGLE AND DOUBLE AUTOLOCK SUPPLEMENT	PAGE	26
13 1.2 METRE CAT DRIVE II INSTALLATION DRAWING	PAGE	27
14 EARLY .9 MTR & 1.00 MTR CAT DRIVE II EXTENSION DRAWING	PAGE	28

Important Advice to Owners of MK2 Sonic Cat Drives

- 1) Please read fully the handbook supplied with your unit.

We draw your attention to the limitations of use depending on the power/torque of your engine installation.

Page 1

- 2) The pre service check out should be adhered to especially checking the oil level, or ensure this is carried out as a pre-delivery check by your dealer/boatbuilder.

Page 6

- 3) Particular note on sea and estuary use.

Page 8

- 3a) The Yoke (item 35) is the most vulnerable component likely to suffer impact damage. This item is usually the first to fail, by design, in most cases. In doing so it protects more expensive components. You may consider this a useful spare part along with your onboard spares kit.

- 4) Running in and first service must be carried out at 20 hours, remember when refilling with oil to check level over a 30 minute period (and keep the receipt from your mechanic for this service, you may need it).

Page 9

(This unit is a slow filler) and remember to check weekly.

Page 11

- 5) In addition check prop shaft. (In the unlikely event of side play existing after running in). If side play exists the shaft will require shimming.

Page 13

- 6) Remember, if your unit extends below the draft of the hulls and you settle in soft sand or mud, any movement in this condition is likely to strain or break the drive, either at the transom plate, or the yoke. Your unit is not designed to take these exceptional loads. Always tilt the unit if in doubt. An important caution for Gemini owners.

- 6a) Also remember that the auto lock system gives you no protection against impact with underwater objects.

- 7) You may consider purchase of an onboard spares kit.

FOREWORD 1

The Sonic MK II Catamaran drive was first produced in 1979 and is a development of its forerunner the MK I Catamaran drive. The MK II drive has been developed to minimise weight and allow the use of standard inboard engine/gearbox combinations and providing charging facilities whilst the unit is tilted when under sail or moored in harbour.

It should be remembered that these units are installed where they are subjected to all weather conditions outside the craft. Therefore regular servicing and care are essential to ensure troublefree use. Attention should be paid to instructions and advice contained in this handbook.

This Catamaran drive is designed for use primarily as a sailboat auxiliary propulsion system, not for a power cat application. Its lightness in construction, is demanded by the sailing enthusiast to maximise sailing performance. Therefore when under power, remember prudence, and you will receive good service.

Technical Specification 1

POWER CAPACITY: S.A.E. ratings (Subject to applications & to be agreed with Sillette in writing prior to use)	+MAX PETROL ENGINE 50 BHP - Subject to torque limits +MAX DIESEL ENGINE 38 BHP - Subject to torque limits +MAX INPUT TORQUE = ENGINE TORQUE X GEAR RATIO = 15 KG/MTR NB Torque in excess of 10 KG/MTR & for longer lengths reverse RPM should be restricted to ½ throttle.
TRANSMISSION	DIRECT DRIVE, GLEASON – SPIRAL GEARS AS STANDARD BEVEL GEARS, 1:1 RATIO ROTATION - REVERSED INPUT TO OUTPUT
PROPELLERS	12 SPLINE DRIVE L OR R HAND 3 BLADE ALUMINIUM, 13" & 14" DIAMETER 17 SPLINE DRIVE L OR R HAND 14" & 15" ALSO 16" FOR SPECIAL APPLICATIONS
STEERING	30° TO PORT OR STARBOARD, OPERATED BY PROPRIETARY PUSH PULL CABLE SYSTEM OR LINKED TO BOOM RUDDERS (SEE NOTE).
MOUNTING AND TRIM	ATTACHED PLATE TO BE MOUNTED TO A SEMI- VERTICAL MOUNTING INCLINED AT 7°-12° ANGLE (TO GIVE HORIZONTAL THRUST) FOR AUTO LOCK 7° ONLY - SEE INSTALLATION DRAWING FIG.1.
TILT	65° MAXIMUM (USING 7° MOUNTING) MANUAL OR HYDRAULIC OPERATION
INPUT TO OUTPUT SHAFT	800, 900, 1000 & 1200MM AS STANDARD Special lengths may be possible.
LUBRICATION	INTERNAL, HYPOID 90 OIL (90 GRADE OIL ONLY) CAPACITY VARIES ACCORDING TO LENGTH IN A RANGE 5-7 LTRS, FILL TO LEVEL STICK (Slow Filler) EXTERNAL, LIBERAL USE OF WATER RESISTANT GREASE
REVERSE LOCK DOWN	a) MANUAL - PULL CABLE TO OPERATE b) AUTOLOCK - PULL CABLE TO RELEASE
WEIGHT DRY	800-50KG, 900-53KG, 1000-55KG, 1200-60KG

INSTALLATION DETAILS 1

- i) MOUNTING ARRANGEMENTS AND INSTALLATION DRAWINGS
- ii) STEERING
- iii) REVERSE LOCKING
- iv) ENGINE COUPLING
- v) PROPELLER
- vi) PRE-SERVICE CHECKOUT

i) MOUNTING ARRANGEMENTS

There are two basic methods of Mounting the unit to the catamaran, Method a) whereby the unit is mounted on top of the bridge deck to a suitable mounting pad, with the leg either projecting through the deck or astern of the deck and equal distant between the booms. The whole installation can then be enclosed in a lift off canopy for ease of servicing. (See Fig 3). This is a relatively simple installation which invariably requires the longer length leg. Method b) is that normally adopted by production boat builders, where a fibre glass pod is mounted below the sternmost part of the bridge deck and equi-distant between the booms, a pad is provided aft of the pod to accept the drive mounting plate, the engine being housed within the pod, access being gained by a hatch on deck. (See Fig 4)

METHOD a)

First ascertain the length of drive required taking into account height of bridge deck above water line using the following method.

LENGTH OF UNIT REQUIRED = HEIGHT OF BRIDGE DECK
ABOVE WATER LINE + 400MM (16") MIN + ENGINE SUMP CLEARANCE
ABOVE DECK + HEIGHT TO GEARBOX OUTPUT FLANGE

Then construct a suitable mounting cradle either using marine ply laminated and hardwood engine bearers, (minimum sizes 40MM /1 $\frac{3}{4}$ ") mounting pad thickness - 300MM/12" wide. Depth to suit, Engine bearers 50MM/2" thick.

The width of the cradle will depend mainly on the engine mounting centres. The drive mounting pad should span the engine bearers, be amply reinforced and tied in by diagonals to the engine bearers which should be cross braced in the middle as well as the ends. The whole cradle then being suitable attached to the bridge deck using spreader plates if necessary to distribute the load if the deck is of a light construction. We do suggest close consultation with Sillette and your boat manufacturer on these points. Another method of construction would be to use a steel fabrication with 50x50x6MM/2x2x $\frac{1}{4}$ " ANGLE IRON BEARERS and 15MM steel mounting plate reinforced by diagonal braces and ties.

The cradle can be mounted on the sternmost part of the deck, whereby the drive is free to tilt astern, or alternatively (subject to confirmation from your boatbuilder) the installation can be brought forward and the drive taken through a hold in the deck.

The size of which should allow for sufficient Aft tilt so as to clear the water when under sail.

METHOD b)

First ascertain input Centre Line in relation to bridge deck (which ideally should be below deck level). Use the following method.

RELATIVE POSITION OF INPUT CENTRE LINE TO BRIDGE DECK =
HEIGHT OF BRIDGE DECK ABOVE WATER LINE + 200MM(16")MIN - LESS 800MM OR
900MM OR 1000MM OR 1200MM MIN DEPENDING ON MODEL.

A positive answer signifies this centre line is below the bridge deck. a negative answer above deck.

From this dimension and those shown in Fig. 1 & 2 together with engine dimensions one can sketch out the size of pod required if not already part of your craft.

The pod can either be constructed of marine ply and glass over or can be of a fibre glass construction to 250 grm (8oz) lay up specifications with mounting pad bounded in to give a 40MM minimum sandwich construction.. The whole pod being suitably attached to the underside of the deck and an aperture cut in the deck to gain access to the pod for engine fitting and future servicing. Bearers should be bounded into the pod at suitable height and centres to take your engine, alternatively a Sillette mounting frame can be fitted, room permitting.

It has been suggested that a suitable sized dinghy be used as a pod, the transom of which could be thickened to 40MM to accept the drive mounting plate, this could then save a lot of time.

Of course if the craft is already fitted with a suitable pod as in the case of Prouts, then the work so far is not necessary.

The pod, or on deck mounting (Methods a and b) being completed, the following procedure should be adopted. Having ascertained the crankshaft centre line height, mark in pencil on the mounting pad, horizontal and vertical lines (see fig 2 points a/c and b/d) then position the template on centre lines and tape in position. Proceed to cut out the 2 apertures with a jig-saw tool, and drill 6 holes 12MM (7/16") diameter as shown on the template. It may be necessary to angle the tiller arm aperture to afford the tiller its full arc. Remove the template and check the mounting face of the pad is flat. Glue "O" ring supplied, into the drive mounting plate groove using "Super Glue", say, 6" at a time. When finally attached, coat the sealing surfaces of the pad and the drive mounting plate with "Selastic" or suitable waterproof mastic. Then offer up the drive unit and bolt in position with six 10MM ($\frac{3}{8}$ ") stainless steel bolts fitted with mudguard washers on the inside, ensure that there is plenty of mastic around the bolts to avoid future leakages and tighten evenly all round.

Fit Sonic anodes to back plate mounting and propeller shaft thrust cap, if not already fitted.

Note for methods a) or b), an additional thrust pad should be provided below the mounting plate, constructed of stainless steel bracketry and faced with a hard wood block positioned and shaped to take forward thrust, in the following situations.

.80 mtr unit, motors exceeding 35HP Diesel

.90 mtr unit, motors exceeding 30HP Diesel

1.00 mtr unit, motors exceeding 25HP Diesel

of course the 1.20 mtr unit is supplied as standard with a lower thrust support.

If in doubt contact Sillette or your local dealer.

FIG 1.

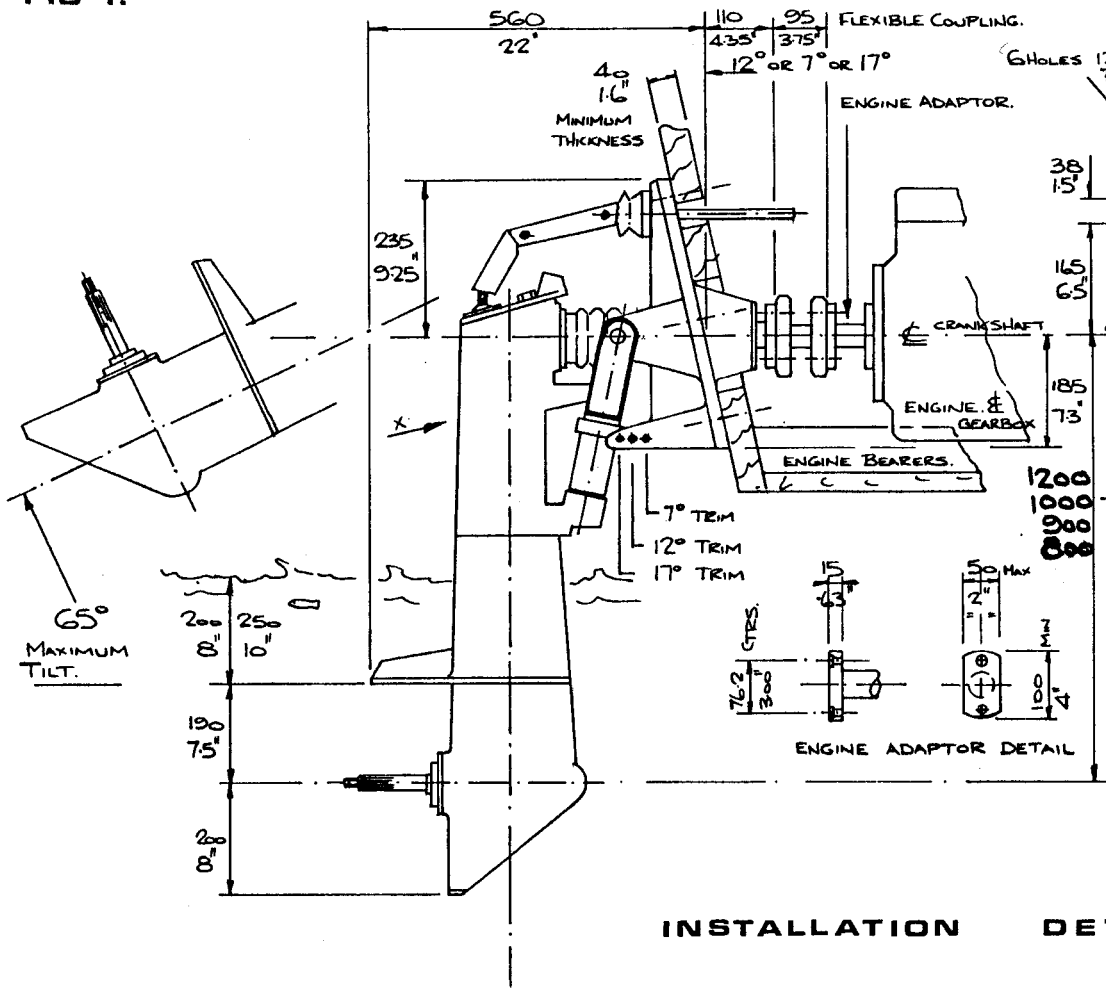
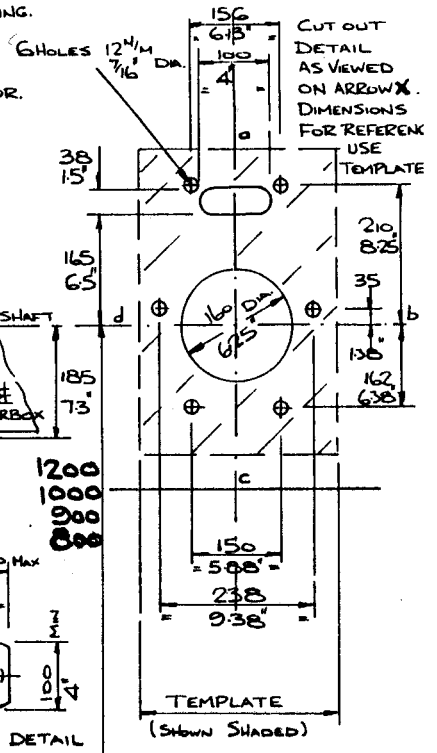
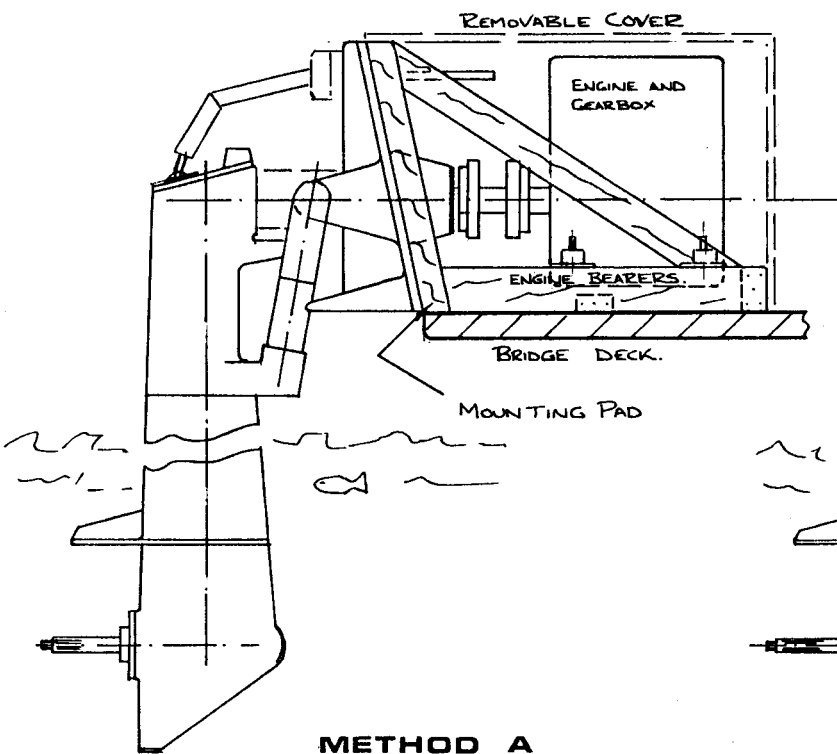

FIG 2.



INSTALLATION DETAILS

FIG 3.



METHOD A
On deck mounting

FIG 4.

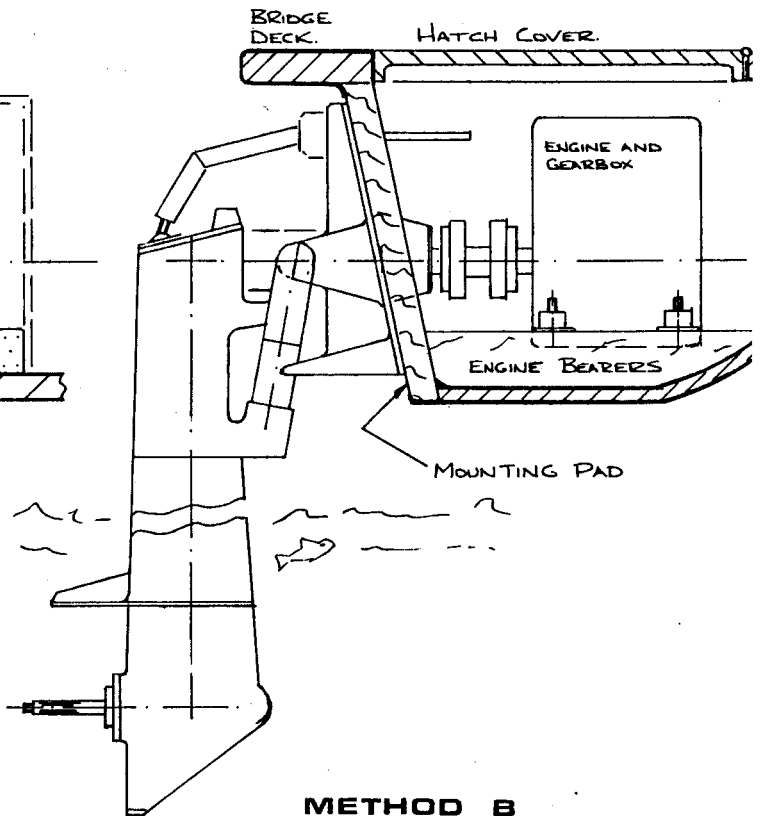

METHOD B
Pod mounted

ii) STEERING

A proprietary push pull cable system can be used independent of the boom rudders either using a separate helm wheel or a stick control type Morse D2 control with UD617 cable. The latter requires the tiller arm to be re-drilled to accept a 150mm (6") stroke cable in lieu of the 230mm (9") stroke used on conventional helms.

Either system is available from Sillette.

Alternatively the drive unit can be steered in conjunction with the boom rudders by means of a connecting link to the boom rudder tie bar or tiller. The point of attachment must not exceed a 9" linear movement to the drive tiller arm. Also the connecting link should have a universal swivel at each end and must have a quick release facility for when the drive is tilted –

NB. The drive can not be steered when in the tilted position.

iii) REVERSE LOCKING – Manual lock and auto lock

This is operated by a 33c cable to port side of the unit and attached to the drive by means of a clamp & shim and by a stainless steel ball joint to the lever – for manual lock. Auto lock, needs only a cable to release and is again a 33c type fed through the transom plate, sealed then with silicon rubber. The outer cable being anchored inboard by a clip bracket, whilst release action is achieved via 2 nuts locked to the inner cable.

For both applications see sketches pages 25 and 26 in the handbook. Both cable kits and advice are available from Sillette.

iv) ENGINE COUPLING

Ensure that when positioning the engine that it is directly in line with the drive flange. Adjustment can be made by either packing under the engine mounting feet or by using adjustable mounts. The engine must always be flexible mounted.

To couple the engine to the Sonic Catamaran drive, a double flexible coupling assembly must be used (available from Sillette) with a two bolt fixing. This is bolted to the drive flange and to the gearbox adapter on the engine. (See Fig 1).

To install engine, first bolt the double flexible coupling to the drive unit, then lift the engine complete with adapter and flexible mounts into position and connect up the flexible coupling. Line up the engine by eye, pack mountings as necessary or adjust to suit. Partially bolt or screw down flexible mountings with suitable fasteners as per your engine suppliers advice. To check alignment of coupling first view from above and from the side, adjust to give visual alignment. Then measure using a packer and feeler gauge or similar between the opposing bolt heads on each side of the coupling whilst the heads are horizontal to each other, then rotate through 90° to a vertical alignment. In all cases the gap should be identical when the engine is in line. Finally, bolt down engine and re-check coupling tightness. Check alignment several times and adjust as necessary. Re-check once the engine has run.

One final check is to measure between 1 set of 2 opposing bolt heads and rotate through 90° - 3 times checking the gap at each ¼ turn – this should not vary more than .01" - .25 mm.

Follow your engine supplier/manufacturer's instructions to complete your engine installation.

v) PROPELLER

Having selected a suitable propeller for the craft (See Chapter 3). Check that the handling is correct for the gearbox you are using, remember the Sonic Catamaran Drive reverses the rotation from input to output. To fit, first grease the propeller shaft with water resistant grease. Fit the spacer followed by the propeller, then locate the tab washer on the splines. Whilst holding the tab washer in situ, screw the nose cone fully home with a suitable wrench and bend back two locking tabs onto the flats on each side of the nose cone.

vi) PRE-SERVICE CHECKOUT

Before launching.

Check all external screws for tightness. Remove oil filler/level plug and fill with oil to level using Hypoid 90 oil. It may be necessary to squeeze the convolute gaiter to aid the oil flow into the mounting plate housing, leave for ½ hour and top up as necessary. To check level, rest the head of filler/level plug on the top cover and take a dipstick reading whilst the craft is level top up if necessary and replace filler/level plug. (NB. Use the correct size box spanner for tightening filler plug – 25mm/1" AF). Available from Sillette.

Lubricate all external pivot points with water resistant grease and check for free movement of all pivot points. Spray cable with 'WD40'. Check drain plug for tightness and re-check mounting bolts. Finally visually check unit for any oil seepage.

After launching.

It is advisable to chock the unit into the full tilt position whilst launching, when in the water remove chock and lower unit.

Having made all necessary engine checks start up engine in neutral, let engine reach running temperature and adjust idling RPM as low as possible, consistent with keeping an even tick over.

With craft safely moored, engage forward and astern gears, remember to engage reverse lock on manual lock models, run in each gear for 5 to 10 minutes, check for any signs of oil seepage. It is necessary to run in new oil seals to bed them in. Stop engine and re-check coupling bolts, engine mountings and alignment. With everything in order and other work being completed, proceed with sea trials taking note of points in Chapter 3 and running in instructions in Chapter 4.

For the auto lock model it is necessary to power the unit into lock once lowered. For example with craft moored lower drive unit, engage ahead and gradually increase r.p.m. until a click from the lock is heard, switch off and ascertain it is safely locked down before re-starting and proceeding to sea trials.

Notes, regarding removal of Sonic Drive oil drain plug #99

1. The plug located in the skeg is ¼" BSPT and uses a ¼" A/F hexagon Allen key to remove. You should use a key with at least 6"/150mm of arm.
2. To remove clean area around the plug, maybe with a wire brush. Insert and fully locate ¼" A/F Allen key and unscrew anti clockwise.
3. If resistance is too great to unscrew, use a steel punch 7/16"/11.5mm diameter about 4"/100mm long, preferably with a raised point one end 3/16" diameter to roughly locate in the hexagon hole. Then, using a large engineers, or club hammer and whilst holding the punch with mole grip, or pliers and whilst supporting the opposite side of the drive leg, holding the punch firmly against the face of the drain plug and with a firm and determined force, strike the punch with the hammer. This may be repeated several times. After each blow, re-insert the Allen key and attempt to unscrew as at 2. **DO NOT STRIKE THE ALLEN KEY WITH THE HAMMER**, as this has little affect and usually damages the hexagon in the plug.
4. If process at 3 fails to remove the drain plug, then apply heat to the aluminium around the plug until "hand hot" to encourage it to expand. Note if you heat the plug it will cause it to expand and become even tighter in the aluminium. Then repeat as at 3.
5. To drain the oil it is necessary to remove the filler plug #616/30.
6. When re-fitting drain plug, use PTFE/Teflon tape and water resistant grease on the threads. Centralise the taper plug into the hole and turn clockwise. Resistance should be light until fully inserted. Note. Being a taper plug it is difficult to cross thread accidentally, as the plug draws itself in on the thread when turned clockwise. **DO NOT USE COPPER BASED ANTI-SIEZE COMPOUNDS** as this causes corrosion in the water environment.

Comment

We at Sillette have never failed to remove a drain plug by methods 2, 3 or 4 unless the hexagon had been previously damaged.

If the hexagon is damaged, the plug can be drilled out using a masonry drill (carbide tipped or similar). Use at low speed with plenty of coolant. Start with a small size, gradually increasing to ⅜"/9.5mm. The remainder of the plug can usually be removed by using an "Easyout" (tool with a left hand spiral, available from any good tool supplier). If however you do not succeed with the "Easyout", continue drilling to 11.5mm diameter and clear remaining plug material using ¼" BSPT or ¼" NPT tap. Note. Ensure twist drill remains central and square when drilling. The oil usually flushes out the drillings. If in doubt flush through with more oil.

If the thread is damaged re-drill to 15mm diameter and re-tap 3/8" BSPT/NPT and fit oversize ⅜" BSPT/NPT taper plug.

Remember "On Board Spares Kit", spare drain plugs and the correct Allen key set are available form Sillette.

HINTS FOR THE HELMSMAN 3

- i) USE OF GEAR SHIFT
- ii) STEERING CONTROL
- iii) TRIM SETTING
- iv) PROPELLERS
- v) SEA AND ESTUARY

i) USE OF GEAR SHIFT

Avoid engaging gear whilst running at more than idle r.p.m. Remember to engage reverse lock before attempting to go astern - preferably before throttling back if you have a remote lock fitted. We suggest a small notice to this affect be placed in the cockpit for the novice helmsman.

ii) STEERING CONTROL

We do not recommend maximum power whilst the unit is on full lock. Always throttle back, steer the craft and apply the throttle to give a smooth turn. Also we do not recommend large additional rudder area to be fitted to the Sonic Drive, as this causes excessive wear on the steering system.

Remember, if your drive unit is connected in Tandem with the boom rudders, it must be disconnected when the unit is tilted, as damage will occur to the steering linkage.

If a remote steering system is fitted remember to keep in the ahead position when tilting the unit for sailing.

iii) TRIM SETTING

The Sonic Catamaran Drive is designed to accept a mounting pad angle of 7° or 12° from the vertical (see Fig 1) or 7° only for autolock models, adjust fully in for a 7° pad and to middle hole for 12° pad.

Always ensure your craft is well trimmed as excessive bow weight will cause the unit to cavitate due to lack of depth in the water. (see Fig 1).

iv) PROPELLERS

The size of propeller you require will depend on the size of engine, gearbox reduction, design speed of craft and tonnage. The diameter of the prop will match the engine size and output RPM whilst the pitch will be calculated to suit the craft and power availability without overloading the engine.

It is very difficult in the first instance to prescribe the exact propeller with so many variants. The results of the first propeller chosen may not be ideal, therefore it is often necessary to try out a second size. The manufacturers are often able to assist in this exercise.

v) SEA AND ESTUARY

When using this drive unit at sea, or in an estuary it is imperative that "Anodes" are fitted (a) around the propeller and (b) to the mounting back plate. If anodes are not fitted serious corrosion will take place. Also ensure that the anodes make metal to metal contact and are not insulated by paint, do not paint over the anode. These anodes are fitted as standard.

If anti-fouling is used on the craft it is important to use a copper free anti-fouling, suitable for aluminium, otherwise corrosion will take place.

Never run the craft at maximum r.p.m. for prolonged periods as this affects the lift of both engine and drive unit.

Never leave the drive unit in its down position if moored when the tide leaves moorings dried out.

The tilt can either be operated by a pulley block system, or the hydraulic lift accessory can be fitted.

Always ensure reverse lock is operative before going astern.

When input torques in excess of 10 kg mtr up to the maximum are used or lengths in excess of 800mm, or propeller size over 14" diameter. The reverse r.p.m. should be restricted to half throttle, and caution observed whilst on full lock, in either ahead or astern.

When going astern, remember if your Sonic drive should impact, there will be a potential for structural damage to the drive. Likewise in ahead especially with the auto lock model – remember this is a lightweight sail boat auxiliary.

Always engage reverse lock (manual system) whilst manoeuvring in harbour, both ahead and astern. When at sea apply lock before reducing throttle, otherwise leg will lift off and the lock will be inoperative.

Slamming of the drive leg must be avoided, likewise impact between drive leg and other objects. This causes a potential for damage.

The yoke item 35 is the most vulnerable component to suffer impact damage this item is usually the first to fail, by design in most cases. In doing so it protects more expensive components. You may consider this a useful spare part along with your onboard spares kit.

SERVICING 4

- i) **RUNNING IN AND FIRST SERVICE**
- ii) **GENERAL SERVICING**
- iii) **WINTERISING AND DE-WINTERISING**

i) RUNNING IN AND FIRST SERVICE

- a) Run the Catamaran Drive for at 20 hours at a maximum of ½ engine r.p.m. during the running in period, i.e. 2500 maximum for petrol engines, 1500 maximum for diesel engines. This should be in general use using both ahead and astern gears. After which the following service should be carried out.
- b) If possible slip or crane out the craft, if this is not practicable partially tilt the unit or work between tides. Remove, drain and filler plug and drain off oil. Check condition for emulsification, if heavily emulsified check cause and rectify, leave to drain for ½ hour and replace drain plug, refill with fresh Hypoid 90 gear oil, leave for 15 minutes and check oil level by taking a dipstick reading with filler/level plug, as previously described, whilst the craft is level. Top up if necessary and replace filler/level plug.
- c) Check tightness of all bolts, screws, nuts etc.
- d) Check tightness of coupling and mounting bolts.
- e) Check all pivot points, latch reverse locking system for free movement and lubricate with water resistant grease, applied with a paint brush. Where convenient remove pins, grease and replace.
- f) Check reverse lock or release cable and lubricate with 'WD40', and water resistant grease.
- g) Check steering for free movement.
- h) Check unit for oil seepage, contact your agent if in doubt.

Refer to Fig 5 for details.

ii) GENERAL SERVICING

The normal periodic attention required is at intervals of 40 hours running or monthly (whichever is the shorter period). However, we recommend a weekly check of the oil level and for signs of contamination (a and b instruction).

Proceed as follows.

- a) Remove dipstick and check oil level by resting dipstick on the top cover. Top up with Hypoid 90 gear oil if necessary.
- b) Check oil for contamination, if this appears excessive, (i.e. the oil has emulsified, in which case it will be much lighter in colour than fresh oil and thinner) ascertain cause and rectify. Replace filler plug, if oil is found to be clean.
NB. Ideally the oil is best checked for emulsification when the unit has been run for ¼ hour.
- c) Check astern lock for correct functioning, either type and lubricate with water resistant grease applied with a paint brush.
- d) Lubricate Astern lock or release cable, with WD40 and water resistant grease, applied with a paint brush.

- e) Check paintwork for signs of damage. Repair and make good if necessary. Check visible zinc anode for corrosion, replace if ½ corroded.
- f) Visually check propeller for damage, if blades are chipped or bent the propeller should be repaired or replaced, otherwise this will damage the propeller shaft bearings and cause vibrations which can lead to other damage.
- g) Check steering linkage and lubricate all cables and links with 'WD40' and water resistant grease.
- h) Check all fasteners for tightness. Check gaiters for damage and seals for oil leaks, rectify if necessary. NB. Gaiters and clips should be replaced every 2 years even if not changed.
- i) Check tightness of mounting bolts and coupling bolts – recheck engine alignment.
- j) Check all linkages and pivot points for free movement and lubricate with water resistant grease, where possible remove pins apply grease and re-fit.

NB. Drive unit oil should be changed every 100 hours or at the end of the season. Use Hypoid 90.

Refer to Fig 5 for details.

iii) WINTERISING AND RE-WINTERISING

At the end of each season the Catamaran Drive unit should be winterised as follows.

- a) Ideally, the craft should be out of the water over winter. If this is not possible, precautions should be taken against freezing water conditions.

NB. Freezing water conditions cause differential contractions with consequence of possible oil leaks in the coming season.

- b) In either case, drain the oil as previously described and refill with a lay up or preservative oil. Check that there are no oil leaks from the unit.
- c) Clean off any scale or weed that may be attached, repair any point defects.
- d) Remove propeller and send away for repair if damaged.
- e) Check anodes, if more than ½ corroded or powdery, replace.
- f) Coat all pivot points with water resistant grease, where possible remove pins coat with grease and replace.
- g) If the boat is on hard standing for the winter, ensure no weight of the hull is resting on the drive unit. If the boat is afloat for the winter tilt the drive. In both cases wrap the Transmission leg with plastic sheeting, tie in place. Lash the leg unit in the full tilt position if afloat for the winter.

To de-winterise, adopt the following procedure.

- a) Unwrap the leg unit and check for any leakage.
- b) Drain, lay up oil.
- c) Check the propeller shaft for free play, if necessary rectify as explained in chapter 5.

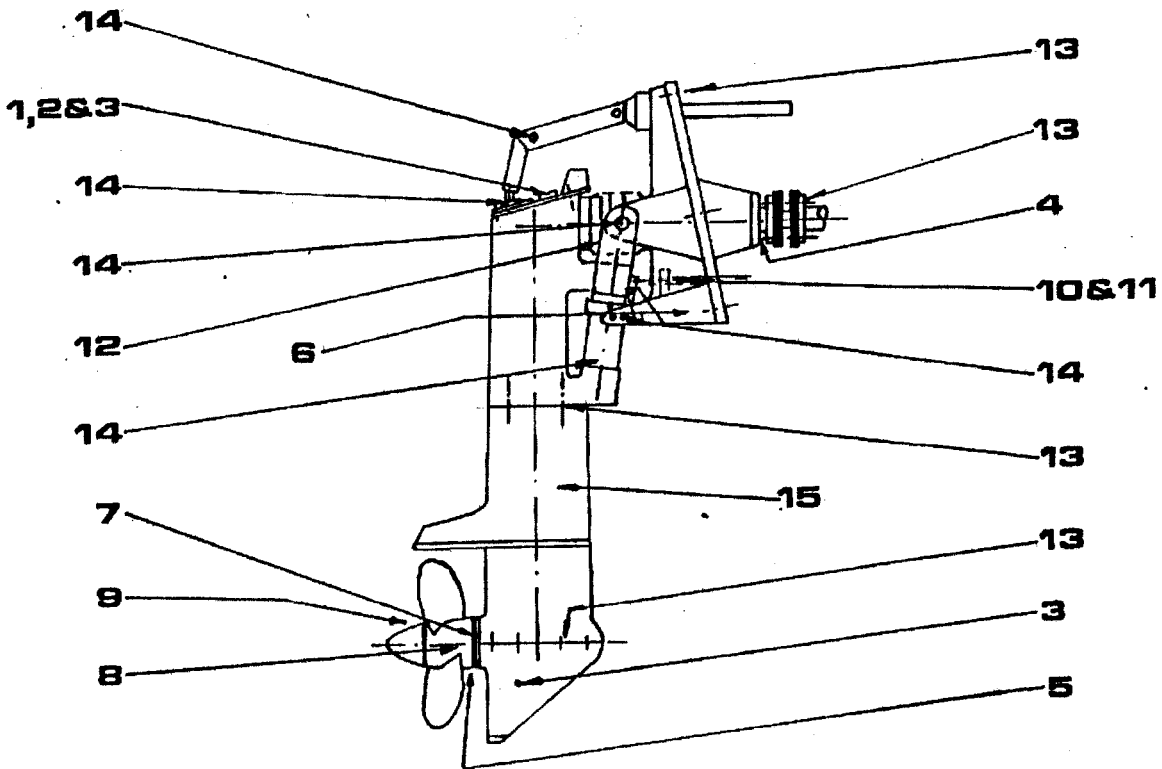

	Instruction	weekly	40 hrs	yearly
1	Check oil level with dipstick filler	•	•	
2	Remove dipstick and check oil for emulsification	•	•	
3	Drain and refill with Hypoid 90 gear oil			•
4	Check input shaft oil seal for leakage	•	•	•
5	Check prop shaft oil sea for leakage		•	•
6	Check visible anode for corrosion		•	•
7	Check prop shaft anode for corrosion			•
8	Check propeller for condition		•	•
9	Remove prop, check prop haft, side play and runout			•
10	Lubricate astern lock cable with WD40 and water resistant grease		•	•
11	Check astern lock cable function		•	•
12	Check gaiter for damage and seepage	•	•	•
13	Check bolts, screws and fasteners for tightness		•	•
14	Check pivot points for free movement and lubricate with grease		•	•
15	Check paintwork for damage and repair if necessary		•	•

- d) Rectify any oil leaks found at a).
- e) Repeat as at c), d), e), g), h), i), j), under General Servicing (ii).
- f) Replace propeller and tab in situ as previously described.
- g) Replace drain plug, sealing threads with 'Instant Gasket',
- h) Refill with Hypoid 90 oil, leave for $\frac{1}{2}$ hour - re-check level, top up and replace filler/level plug, sealing threads with 'Instant Gasket'.
- i) Check oil seals for seepage.

Refer to Fig 5 for details.

GENERAL INFORMATION 5

- i) USE OF LOCTITE AND INSTANT GASKET
- ii) PROPELLER SHAFT BEARING ADJUSTMENT AND SEAL REPLACEMENT
- iii) INPUT SEAL REPLACEMENT
- iv) REVERSE LOCK SET UP, ALL MODELS
- v) CHANGING CV. BELLOWS ITEM 62

i) USE OF LOCTITE AND INSTANT GASKET

(Both available from the manufacturers)

When fitting bearings, screws and fasteners, loctite must be used as follows: -

- a) Degrease both mating parts with loctite primer 'T' or cellulose thinners. Allow 5 to 10 minutes to cure/dry.
- b) Apply a minimal film of loctite bearing fit, or equivalent to one of the mating parts and spread evenly over the contact surface.
- c) Fit mating parts together and allow to cure for two to three hours without disturbing.

All jointing surfaces of your Sonic are sealed with Hermatite 'Instant Gasket'. It is therefore, imperative that these are re-sealed, should you have cause to break the seal.

Sealing procedure as follows: -

- d) Thoroughly clean jointing surfaces and check for score marks.
- e) Make up gasket if one was previously fitted.
- f) Apply 'Instant Gasket' to both surfaces and fit gasket, if required.
- g) Fit the two mating parts together (do not fully tighten, say, within $\frac{1}{2}$ a screw turn), leave for one hour to cure. Wipe off excess 'Instant Gasket'.
- h) Finally, tighten down and trim excess 'Instant Gasket' with a knife.

ii) PROPELLER SHAFT BEARING ADJUSTMENT AND SEAL REPLACEMENT

REFER TO FIG.7.

- a) Remove propeller.
- b) Check for free play on propeller shaft (i.e. side movement).
- c) Drain oil.
- d) Unscrew 4 screws, (Item 87), and 8 screws, (Item 88).
- e) Remove skeg, (Item 34), and propeller cap, (Item 38), a tap with hide mallet is required to break seal.
- f) The prop shaft, (Item 11), is then free to drop downwards complete with bearings and gear.
- g) Check bearings for damage. Replace if necessary, polish shaft (11) where seals have been running. If worn by seals replace shaft.
- h) It is advisable to replace the two shaft oil seals, (Item 53), at this stage, these are housed in Item 38 and should be driven out as a pair.
NB. They are mounted back to back.
- h)i) Anode replacement is best carried out at this point, drift out through from seal side, clean up housing and top in a replacement anode.

- i) Clean seal housing and press in new seals back to back. Apply waterproof grease to O/D of seal before fitting and to seal tips after fitting.
- j) Remove gasket shims from behind flange of (Item 38) cap – clean up all mating faces, or add shim between cap (38) and bearing (51).
- k) Bind masking tape around splines of prop shaft and form a lead onto the sealing diameter. Slide prop cap (item 38) onto shaft (11) over tape.
- l) Offer up to leg casting (item 33) and check gap behind cap flange, (item 38) and mating face with bearings suitably loaded, using a feeler gauge, then make up gasket shims to .005” more if shimming between the cap (38) and bearing (51).
- m) Refit items 11 and 38, fitting shim gaskets and sealing with ‘Instant Gasket’.
- n) Tighten up screws (items 87 and 88) evenly.
- o) Lightly tap end of prop shaft (item 11) to seat.
- p) Check for any side play and that the shaft will turn with a slight resistance.
- q) If side play exists, remove shim gaskets, .005” at a time and repeat m to p. If shaft will not turn, add shim gaskets .005” at a time. The reverse will apply if shimming between cap (38) and bearing (51).

In either case then repeat m to p.

- r) Refill with Hypoid 90.
- s) Replace propeller.

iii) INPUT SEAL REPLACEMENT

NB. Leaving unit in situ.

- a) Disconnect flexible coupling from drive flange (9) and release engine mountings, move engine forward 75mm/3” and remove flexible coupling complete. Syphon out 1 ltr of oil from the Sonic Drive unit through the filler plug hole.
- b) Holding flange (9) from the turning, unscrew and remove nut and washer (75) and (76) using 15/16” AF box spanner.
- c) Tap flange (9) forward and out of housing.
- d) Unscrew 4 Allen screws (80) and tap out retaining cap/seal housing 43.
- e) Press out old seal (52) using a 62mm/2 7/16” dia drift.
- f) Clean up seal housing and mating face of mounting plate (39).
- g) Fit replacement seal (52) pressing in from outer face of seal housing (43) note correct way round, (See Fig 7) and leave seal flush with outside face, use water resistant grease to aid assembly of seal to housing.

FIG. 6A.

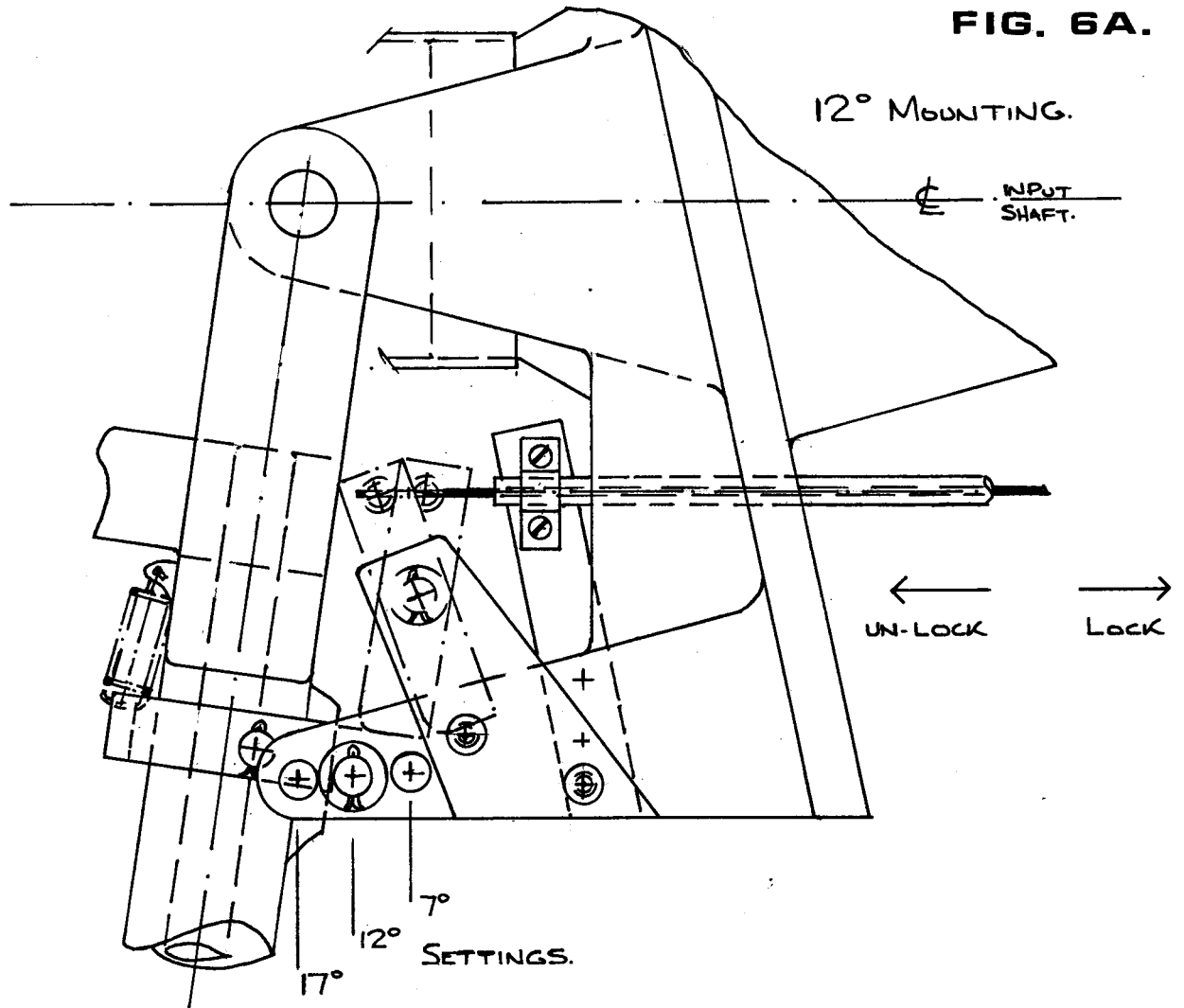
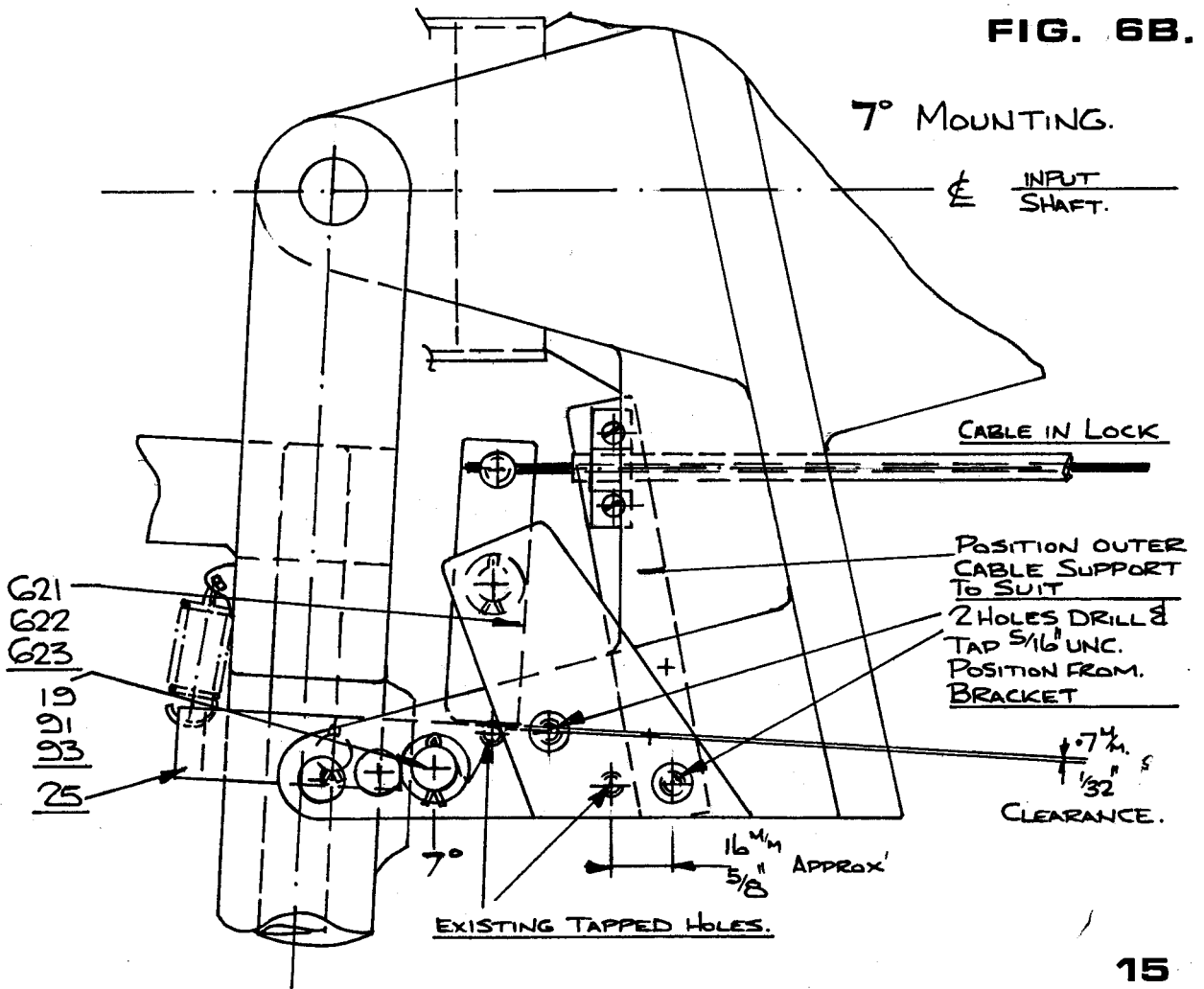

FIG. 6B.



h) Apply water resistant grease to seal lip (52) and apply 'Instant Gasket' to sealing face of retaining cap/seal housing (43) and re-fit using 4 Allen screws 80.

i) Polish seal groove in flange (9) with wet and dry, grade 380 and apply water resistant grease.

j) With a colleague holding the CV joint (46) in position through the gaiter (62) outside the craft, refit the flange (9) first engaging the splines and finally tapping home with a hide mallet very carefully.

k) Refit nut and washer (75 and 76) and loctite in situ.

l) Refit coupling and re-align engine in position.

m) Top up drive unit with Hypoid 90 gear oil and replace filler/level plug (616).

n) Bed in seal for 1 hour at ½ throttle and check for leaks, if OK proceed with normal use.

iv) REVERSE LOCK SET UP – MOST MODELS TO 1984

See sketch Fig 6A for close up of locking mechanism. As standard, the pivot bracket assembly (621, 622, 623) is set up for a 12° mounting plate installation. 7° and 17° installations require the bracket to be re-mounted either nearer or further from the craft along the lug of mounting plate (39), ⅝" either side of the 12° mid position. It is advisable to have this pre-set by the factory prior to purchase, however, should you require to do this at a later stage proceed as follows.

a) The unit being set for 12°, it is necessary to convert for say, 7°. First remove bracket assembly (621, 622 and 623) and disconnect stop cable.

b) Remove rest bar assembly (19, 91 and 93) and refit in the hole nearest the craft.

c) Allow the drive to clip onto the new position. Offer up the bracket assembly (621, 622 and 623) hinge the lock bar into the lock position as shown in Fig 6B, leaving 1/32" clearance to the top of the latch (25). The bracket assembly should now be approximately ⅝" closer to the craft. Clamp the bracket in this position with a suitable 'G' clamp.

d) Transfer the two mounting holes, drilling ¼" dia in the back plate (39), in line with the counterbored holes in the bracket. Then tap 5/16" UNC Allen screws and clean out threads.

e) Refit two 5/16" UNC Allen screws and loctite in position.

f) Reconnect and synchronise stop cable, repositioning clamp if necessary.

For a 7° mounting, repeat as above, only move bracket and rest bar further from the craft instead of towards.

NB. Stop cable fitting instructions, either synchronised or remote are supplied with cable assembly accessory from Sillette.

iv) CONTINUED – MANUAL REVERSE LOCK, GENERALLY FROM 1984

Introduced in 1984 this lock system is mounted on the port side of the transom plate 39, it is possible to convert to this system with the aid of engineering drawing for item 39, supplied when purchasing the necessary conversion part; referred to as items 330-339, see page 25 for detail of the assembly. The system is operated manually by a 33c cable, with 'T' handle conversion inboard which should be mounted horizontally. A tube cut through on one side can be used to drop over the 'T' handle rod to form a positive lock once pulled out by hand. The lock cable, 'T' handle and mounting accessories are available from Sillette in a kit form. This lock system can be used with 7° and 12° mounting face angles. The lock assembly being positioned to suit either 7° or 12° trim setting, see assembly drawing on page 25 for detail. It is important that the correct mounting holes are used for each trim setting. A shim is also provided for mounting between items 330 and 39 if necessary to limit the clearance between items 332 and 25, for fine and necessary adjustment.

iv) CONTINUED – AUTO LOCK SUPPLIED AS AN OPTION FROM 1990

This system was introduced to avoid the helmsman forgetting to engage lock when going astern. It too can be retrofitted to all models with the aid of a drawing. See page 26 for detail of the system, which operates only in the 7° trim position, originally supplied to operate on the port side, as per the above. During 1994 a double claw system was developed to handle larger engines, which the boatbuilders wished to fit. To operate both systems the leg is lowered and powered into lock. From which it is restrained at all times until released by operations a 33c cable, and 'T' handle system, which should be fully depressed again once the leg is released and lifted. Please note the return spring on the assembly can not be relied upon to pull the 'T' handle home. This should be pushed in by hand. Fitting of the cable system to the lock is clearly shown on page 26. Due to the number of moving parts on this assembly it should be regularly checked for correct functioning and lubricated with water resistant grease applied with a paint brush.

Important – Never work in close proximity of the rotating propeller.

v) CHANGING CV BELLOWS ITEM 62

The above can be carried out either ashore or afloat the latter of course with more difficulty. First drain down the oil to below the level of the bellows via the drain plug or by siphon pump from filler hole. Disconnect the steering linkage outside the boat either by removing pin no 17 retained by a socket grub screw or disconnect at the ball item 29 by removing the ball cap item 27.

Disconnect tilt cylinder anchorage to the leg or tilt rope if fitted.

Whilst supporting the weight of the leg remove 2 pins no 14 which are retained by one or 5/16" socket screws. Unclip the old CV bellows on the leg side and slide the leg assembly sternwards taking care to catch the floating connecting shaft no 8 within the CV bellows.

Remove the old CV bellows 62 by removing the second clip. Thoroughly clean and degrease the mounting diameters for the CV bellows. Fit new bellows 62 to the transom side first, largest diameter to the transom plate and tighten clip. Fit shaft no 8, with assistant offer up leg to the shaft no 8 and slide home, re-fitting pins no 14. Re-clip bellows to leg side, re-fit all retaining screws to pin no 14. Re-connect steering linkage. Top up with oil, check for leaks. NB. Use water resistant grease replacing pins and socket screws.

HYDRAULIC TILT SUPPLEMENT 6

- i) INSTALLATION
- ii) OPERATING INSTRUCTIONS
- iii) PERIODIC SERVICING

i) INSTALLATION

- a) Attaching Hydraulic Ram to Sonic Drive. (If purchased separately).

First bolt rear pivot in position, (215, 213 and 212) on Transom plate lug (39), which is already pre-drilled to drawing, using loctite as previously described. Ensure that the pivot anchor is square to the centre line of drive unit when finally bolted in position.

Attach ram to rear anchor and retain with bolt and washer (211, 213). Align from pivot (214) to piston rod with 2 - 3/32" diameter split pins. Then ensure that both pivots are parallel, position front pivot to steering yoke (35) below life pivot centre line as Fig. 5. Then transfer the two holes from the front pivot (214) to the yoke (35) - drilling first 5MM and then tapping $\frac{1}{4}$ " UNC x $\frac{3}{4}$ " deep. Finally, bolt the front pivot (214) in position using 2 - $\frac{1}{4}$ " Allen screws supplied, not forgetting to use loctite as before. Refer to Fig. 8 for further information.

- b) Applies to all applications.

Mount the hand pump in position using the 2 - $\frac{5}{8}$ " holes provided and ensure that there is sufficient space for the hand lever to be operated through its full stroke. The pump should be mounted upright in a position higher than the stern drive. If the position of the nylon filler plug on the pump reservoir is in an inaccessible position, it is permissible to slacken the knurled cap on the bottom of the reservoir and rotate the reservoir to a more convenient position, then tighten the knurled screw.

- c) Route the flexible hose through the craft between the hand pump and the stern drive unit. Ensure that the pipe does not pass around any sharp edges or in any position where it may become punctured or kinked and then clip in position to avoid chaffing. Ensure that the hose passes through the Transom at a minimum of 14" above the water line.

- d) Remove the plastic caps from the hose end fittings, hand pump union and tilt ram union, then connect one end of the hose to the pump and tighten firmly.

- e) Remove the nylon filler plug from the reservoir and fill to the level with hydraulic power steering fluid/ATF (This fluid is less damaging to paintwork than conventional hydraulic fluid and is suitable for the seals in the system).

- f) Ensure that the lock and release knob on the pump is screwed closed. Operate the pump until fluid is seen at the opposite end of the hose, then connect this end to the tilt ram union outside the craft and tighten firmly.

- g) Release reverse lock top up hydraulic reservoir and continue operating the hand pump until the leg unit is half raised then slacken release knob $\frac{1}{4}$ / $\frac{1}{2}$ turn to allow the leg to lower itself naturally.

- h) Close release knob and top up the reservoir.
- i) Pump the leg to its full tilt position and lower as before.
- j) Repeat the procedure twice more to remove most of the air trapped in the system. (if not, repeat until clear).
- k) Top up reservoir in the lowered position and replace nylon plug, clean away any excess fluid.
- l) Ensure that the lock and release knob is closed at all times except for lowering the unit.
- m) Smear all external pivot points, hose end and the piston rod when fully extended. Use water resistant grease.
- n) Finally, fit vent pipe to the piston rod end of ram and pass through Transom into the engine compartment at a minimum of 14" above water level.

ii) OPERATING INSTRUCTIONS

- a) With craft at rest and drive unit reverse lock disengaged, ensure lock release knob is fully tightened, pump the operating level approximately fifteen to twenty times to achieve full tilt, heavy resistance will be felt when the leg has reached full tilt.
- b) To lower, unscrew the lock/release knob $\frac{1}{4}/\frac{1}{2}$ turn and allow the leg to lower under its own weight, check the unit is fully down and close the lock release knob.
- c) Do not raise the leg whilst the craft is underway. Do not attempt to raise the unit whilst in astern gear. Do not hurry the pumping operation but maintain a steady and even pumping action. When trailing do not rely upon the hydraulics to hold the unit up, always chock and rope the unit in position. (This also applies to the manual tilt mechanism).
- d) This tilt method is intended for maintenance purposes and fine weather sailing. For bad weather conditions where slamming is encountered the drive leg should be lashed in the tilt position, to avoid strain to the hydraulic components.
- e) There is a secondary valve fitted to the right of the pump this should be closed once fully tilted to avoid creep. Open again when lowering.

HYDRAULIC PUMP & CYLINDER INSTALLATION

FIG. 8.

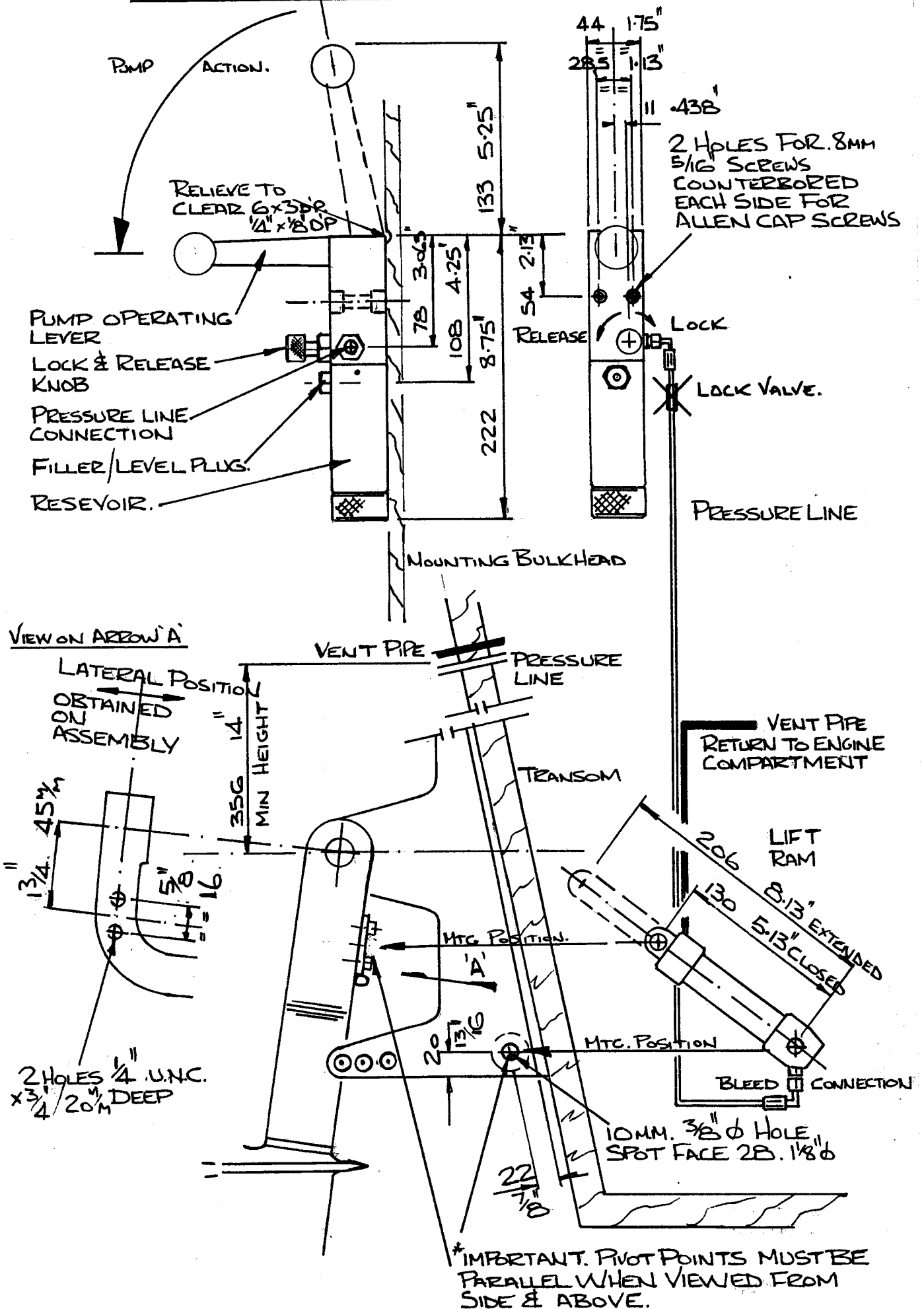

iii) PERIODIC SERVICING

After the initial running in period of your unit and thereafter every thirty hours running or monthly (whichever is the shortest period).

- a) Pump unit to full tilt position, leave for 5 minutes and check unit for any substantial lowering.
- b) Whilst on full tilt check tightening of the lift ram anchor mounting bolts and hose connections. Then grease piston rod, anchor pivots and hose ends with water resistant grease.
- c) Lower unit and check reservoir by running filler/level plug, top up with hydraulic fluid to filler level, then replace plug and tighten. Use propriety oil can (well cleaned) for topping up.
- d) Spray hand pump moving parts with WD40 (ie. Lock release screw and operating lever pivots) wipe away excess fluid.
- e) Apply several drops of Sonic hydraulic fluid into open end of breather/vent pipe.
- f) Check tightness to hose union to pump and also pump mounting bolts.

NOTE

The operating pump consists in part of two none return valves each operating in conjunction with the pumping action transmitted to the piston rod. If any dirt or foreign matter enters the hydraulic system either one of the two none return valves could become inoperative, this symptom would be recognised by a loos of resistance when operating lever is pumped during normal use. To remedy this situation, it is necessary firstly to examine the none return valves (this should be carried out only by a qualified Sonic mechanic or under strict guidance of the manufacturers), for signs of foreign matter and/or damage to the valve seats. It may then be necessary to re-seat the valves and also flush the system to remove further foreign matter. It is therefore, imperative that strict cleanliness is maintained whilst carrying out this operation.

MK II SONIC CAT DRIVE, SPARES LIST

ITEM DESCRIPTION

3 PROPELLER SHAFT GEAR
 4 VERTICAL SHAFT GEAR
 8 SPLINED CONNECTOR
 9 INPUT FLANGE
 10 TILLER ARM
 11 PROPELLER SHAFT
 13 SWIVEL PIN
 14 LIFT PINS
 17 STEERING PIN
 18 TILLER PIN
 19 REST BAR
 20 LATCH PIN
 25 LATCH
 27 BALL CAP
 29 STEERING BALL & STUD 626
 34 SKEG CASTING
 35 STEERING YOKE
 38 PROP CAP
 39 TRANSOM MOUNTING PLATE
 43 BEARING CAP TRANSOM END
 46 TRANSOM CV JOINT
 47 BALL RACE - 30
 49 BALL RACE - 40
 50 BALL RACE - 35
 51A AC BALL RACE - 30
 51B TAPER ROLLER - 30
 52 TRANSOM PLATE OIL SEAL
 53 PROP SHAFT OIL SEAL PAIR
 60A CV CLIP - 90
 60B CV CLIP - 100
 61 TILLER CLIP
 62 CV JOINT GAITER
 63 TILLER GAITER
 64 3/4" DU BUSH 1/2" OR 3/4" LONG
 66 1/2" HEADED NYLON BUSH
 67 3/4" NYLON WASHER
 68 5/8" NYLON WASHER
 70 BUMP RUBBER
 73 LATCH SPRING
 74 NAME PLATE
 75 5/8" NUT
 76 5/8" WASHER
 77 BOLT HEX 1/4" X 3/12" LONG
 78 MUDGUARD WASHER
 80 ALLEN SCREW BLACK 1/4" X 3/4"
 85 HAMMER DRIVE SCREW
 86 OWNERS HANDBOOK
 87 ALLEN SCREW STAINLESS 1/4" X 3/4" LONG
 88 ALLEN SCREW STAINLESS 1/4" X 1" LONG
 89 GRUBSCREW STAINLESS
 90 LOCK NUT STAINLESS 3/8" OR 1/2"
 91 3/8" WASHER STAINLESS
 93 1/8" SPLIT PIN
 94 3/32" SPLIT PIN
 95 PAINT SPEC ETCH PRIMER
 AND TOP COAT
 97 GASKET MATERIAL & SHIM
 98 SEALAND & LOCTITE REPAIR KIT
 99 DRAIN PLUG
 105A GRUBSCREW 5/16" X 3/8"
 105B GRUBSCREW 5/16" X 3/4"
 106 ALLEN SCREW STAINLESS
 1/4" X 1/2" LONG
 107 SONIC LABEL
 113 LABEL SERIAL NO
 120 LARGE PROP SHAFT 17SP
 200 FRONT CAP
 201 REAR CAP
 202 CYLINDER BODY
 203 PISTON
 204 BLEAD FITTING
 206 'O' RING 1"
 207 'O' RING 15/16"
 208 'O' RING 1 1/4"
 209 SPLIT PIN 3/32"

ITEM DESCRIPTION

210 ALLEN SCREW 5/16" X 1" L
 211 HEX BOLT 3/8" X 1/2" L
 212 HEX BOLT 3/8" X 1 1/2" L
 213 WASHER 3/8"
 214 FRONT PIVOT
 215 REAR ANCHOR
 216 MALE ADAPTOR
 217 DUST PLUG F
 218 DUST PLUG M
 219 1/4" BALL
 220 RELIEF BUSH
 221 RELEASE SCREW
 222 RESERVOIR
 223 PICK UP TUBE
 224 PISTON GUIDE
 225 OUTLET
 226 SPACER
 227 RETURN TUBE
 228 RELIEF SCREW
 229 HANDLE
 230 BODY
 231 RESERVOIR BASE
 232 PISTON
 233 3/16" BALL
 234 'O' RING 1 5/8"
 235 MAIN SEAL
 236 'O' - RING 1/4"
 237 NYLON PLUG
 238 PIN 1"
 239 PIN 1 1/4"
 240 SPRING 3/16"
 241 PLASTIC BALL 1"
 242 PLASTIC BALL 1 1/2"
 243 FIBRE WASHER 1/4"
 244 CIRCLIP 7/8"
 245 CIRCLIP 1/4"
 246 BALL RETAINER
 247 BREATHER HOSE
 248 MAIN HOSE - 12 FT
 249 ELBOW FITTING
 250/251 OPTION 1.25:1 GEARS PAIR
 252 NOSE CONE SMALL SHAFT
 253 NOSE CONE LARGE SHAFT
 254 SPACER SMALL
 255 SPACER LARGE
 256 TAB WASHER SMAL
 257 TAB WASHER LARGE
 258 PROP SHAFT ANODE
 259 TRANSOM ANODE
 262 METALASTIC COUPLING (1 Disc)
 263 HT BOLT 7/16" x 4"
 264 HT BOLT 7/16" x 2 1/2"
 265 NUT, NYLOC 7/16"
 266 BRIDGE BAR
 272 BALL JOINT FOR MORSE
 273 MORSE CABLE ANCHOR
 274 ADAPTOR & SPACER 12 TO 17 SPLINE
 282 HURTH GEARBOX ADAPTOR
 283 YANMAR GEARBOX ADAPTOR
 284 VOLVO GEARBOX ADAPTOR
 285 DISTANCE SHAFT UP TO 800mm
 286 HALF COUPLING FOR METALASTIC
 287 FLYWHEEL BARS
 288 DOUBLE ENDED LEVER
 330 332, 334, 339 & 331 MANUAL
 LOCK ASSEMBLY LATE TYPE
 600 CONNECTING SLEEVE
 601 TOPLEG CASTING
 602 BOTTOM LEG
 603 EXTERNAL CIRCLIP
 604 TOP VERTICAL SHAFT
 605 BOTTOM VERTICAL SHAFT
 606 SINGLE VERTICAL SHAFT
 607 CV SHAFT GEAR
 608 CV GEAR SPACER

ITEM DESCRIPTION

609 BALL RACE
 610 HEX BOLT 3/8"
 611 WASHER ST STEEL 3/8" Ø
 612 41 + 17 STEERING LINK ASSY
 613 BEARING HOUSING
 615 LID
 616 FILLER
 620 WASHER 3/8" DIA
 621 LOCK CASTING
 622 ALLEN SCREW 5/16" X 3/4"
 623 PIN PIVOT LOCK
 624 LOCK CABLE HOLDER
 631 UPPER VERTICAL SHAFT 4"
 632 UPPER VERTICAL SHAFT 8"
 633 EXTENSION CASTING 4"
 634 EXTENSION CASTING 8"
 635 LOCATION PIVOT
 636 EXTENSION CASTING 16"
 637 SADDLE
 638 LOCKING BOLT
 639 CABLE SLEEVE
 640 REVERSE CATCH
 641 TOP VERTICAL SHAFT
 642 COLLAR
 643 RETAINING PIN
 645 LOCKING SCREW
 646 GREASE NIPPLE
 647 PADS
 648 SLEEVE SPACER
 649 CAP SC 3/8" X 1 3/4"
 650 HEX NUT
 651 VERTICAL UPPER SHAFT
 652 SINGLE AUTOLOCK
 653 LATCH 7/16"
 654 REST BAR 7/16"
 655 STOPS
 656 NUT 1/4"
 657 WASHER 7/16"
 658 SHIM PLATE
 659 DOUBLE AUTOLOCK
 660 SHIM MAT 72MM
 661 TOP LEG CASTING .9 MTR
 662 ALLEN SC HT 1/4" X 1/2"
 663 ALLEN SC AZ 1/4" X 1 1/4"
 664 SHAKE PROOF WA 1/4"
 665 SHIM MAT 62MM
SPIRAL BEVEL GEAR ITEMS 1998
 700 PINION RH
 701 PROP GEAR LH
 702 INPUT GEAR LH
 703 INSIDE BRG HSG
 704 SPACER SLEEVE
 705 CSK WASHER
 706 BOTTOM VERT SHAFT
 707 UPPER VERT SHAFT .8
 708 UPPER VERT SHAFT .9
 709 UPPER VERT SHAFT 1.0
 710 UPPER VERT SHAFT 1.1
 711 UPPER VERT SHAFT 1.2
 712 CSK SC M10
 713 BALL RACE Q30
 714 BALL RACE Q.875"
 715 BALL RACE Q35
 716 WASHER 5/8"
 717 BEARING 30 x 72
BEARING SYSTEM FROM 2002
 718 INSIDE BEARING HOUSING HD
 719 .8 Mtr TOP LEG HD
 720 .9 Mtr TOP LEG HD
 721 BOTTOM LEG HD
 723 1.2 EXTENSION HD
 724 DOUBLE A.C. BRG 07.HD
 725 DOUBLE A.C. BRG 06.HD
 726 TAPER ROLLER 87x10x HD

SONIC MK II CATAMARAN DRIVE

ACCESSORIES

Nose Cone assembly including Tab Washer - Specify 12 or 17 spline type
Tab Washer - Specify 12 or 17 spline type
Flexible Coupling Kit including Bolts - Metalastic double type
Polymer type available as a spare part - Specify when ordering

Gearbox Adapter including Bolts for fixing to Rubber Coupling.
Prices on application. State Engine & Gearbox when ordering.

Propellers as listed (diameter x pitch) all three Blade aluminium with cushioned hub. Left or right hand.

13"x14"- 12 spline		14"x15" - 17 spline	15"x15" - 17 spline	16"x16" - 17 spline
13"x13"- 12 spline	14"x14"- 12 spline	14"x14" - 17 spline	15"x14" - 17 spline	16"x14" - 17 spline
13"x12"- 12 spline	14"x13"- 12 spline	14"x13" - 17 spline	15"x13" - 17 spline	16"x12" - 17 spline
13"x11"- 12 spline	14"x12"- 12 spline	14"x12" - 17 spline	15"x12" - 17 spline	
13"x10"- 12 spline	14"x11"- 12 spline	14"x11" - 17 spline	15"x11" - 17 spline	
13"x 9"- 12 spline	14"x10"- 12 spline	14"x10" - 17 spline	15"x10" - 17 spline	
13"x 8"- 12 spline	14"x 9"- 12 spline	14"x 9" - 17 spline	15" x 9" - 17 spline	

Anodes for Propeller Shaft and Transom Unit.

Transom Mounting Bolts.

Hydraulic Tilt Kit, hand hydraulic or electrohydraulic.

Manual release cable and fittings for Autolock systems - specify length of cable.

On-board Spares Kit - standard or with yoke item 35.

Instant gasket.

Water resistant grease.

Long series inch Allen keys.

Tube spanner/wrench for filler plug.

Also available: -

1. Steering Systems - Morse.
2. Gear Change Controls - Morse.
3. Marine Engines to order, Yanmar, Lombardini, Beta.
4. Complete Transmission packages, petrol or diesel.

For service and spares

Sillette-Sonic Ltd

Unit 2, Beverley Trading Estate, 190-192 Garth Road

Morden, Surrey, SM4 4LU, UK

e-mail: sales@sillette.co.uk

website: www.sillette.co.uk

Telephone: +44 (0)20 8337 7543

Fax: +44 (0)20 8330 9014

Should you require any further assistance, advice or details, do not hesitate to contact Sillette.

The manufacturers and distributors reserve the right to alter any specification, instruction or dimension without prior notice.

Always remember this is a sailboat auxiliary propulsion system.

Instructions for removal and replacement of Steering Yoke, item 35

- 1) If unit is installed, have the boat lifted, as any oil deposits on the water may result in prosecution by the Local Port Authority.
- 2) Drain down oil by removing Drain Plug 99 and Filler Plug 616/30 and replace after draining. Use PTFE/Teflon tape on the Drain Plug.
- 3) Remove 2 screws 105B from Item 39 Transom Mounting Plate. Use 5/32" (4mm) Allen Key.
- 4) Disconnect Steering Arm. Usually easiest at the ball end by removing 3 screws 106 and lifting clear of the socket in the Lid. (For Gemini Owners, remove the steel bracket from the Lid 615).
- 5) If Lift Cylinder/Ram is fitted for raising the unit. Remove the rod end connection by removing 2 X item 87 screws, using a 3/16" Allen Key.
- 6) Disconnect C V J Bellows (Gaiter) nearest to the leg by removing clip 60A.
- 7) Whilst supporting the weight of the leg, drift inwards the 2 X Lift Pins item 14 to remove. The leg can now be removed by sliding out from the C V J Bellows 62 and Splined Connecting shaft item 8 (Take care not to drop the connecting Shaft overboard).
- 8) Whilst supporting the leg, remove horizontal Latch Pin item 20, having first removed one split pin and drift through.
- 9) The Centre Pin item 13 can now be removed. If the unit is relatively new, screw in a 3/8" UNC (National Course) bolt into the top of the pin and pull upward. If the unit has been in service for any length of time, it will be necessary to use a "Draw, or Slide Hammer" with a 3/8" UNC thread.
- 10) With Centre Pin 13 removed, the Yoke 35 can be removed, taking care not to loose the 2 X nylon spacing washers item 67.
- 11) If fitted, remove Latch 25/653 and spring 73 from the yoke and re-attach spring to the new Yoke
- 12) Fit Yoke 35 in place with the same spacing washers top and bottom using water resistant grease on the surfaces, clean and re-grease Centre Pin 13 and push into position, ensuring the cut out for the Latch Pin 20 is in line with the 3/8" cross hole.
- 13) Re-fit latch with pin 20 (latch not used on 1.2 Mtr units, pin only) re-fit split pin and check Yoke for free movement.
- 14) Consider replacing C V J Bellows (Gaiter) 62 if more than 1 year old. If re-fitting existing Bellows, ensure it is thoroughly degreased.
- 15) Offer leg into position, engaging splines of item 8 Connecting Shaft within the CV Joint. Once in position, grease and re-fit Lift pins 14 and lock in position with 2 X 5/16" screws 105B (use grease on the threads for cat drives, or degrease and loctite on Sterndrives).
- 16) Re-Connect C V J Bellows 62 with C V Clip 60A, ensuring it is secure and neatly in position.
- 17) Re-fill with EP90/Hypoid 90/SAE 90-grade gear oil and remember it can be slow to fill. Check level after two hours and top up as necessary to level on dipstick of plug 30/616. Check twice more before assuming it to be full. Squeeze the C V J Bellows to assist removal of air from within the Transom Mounting Plate. Do not overfill.
- 18) Re-connect the Steering ball (or steel bracket on Gemini) by re-fitting 3 screws 106 into Ball retaining plate (or bracket).
- 19) If a Lifting Cylinder is fitted. Position the rod end bracket so that the pivot point is 2 5/8" (67mm) below the centre of the lift pin 14. (See diagram on Page20 of handbook for actual hole position. The 1 3/4" (45mm) dimension shown should be 1 5/8" (41mm) on a catamaran drive). Ensure it is square and in line as shown and drill two holes into the Yoke 35, 13/64" (5.2mm) diameter X 1" (25mm) deep and tap 1/4" UNC (National Course) X 3/4" (19mm) deep. NB It will be necessary to raise and support the leg to gain access for your drill & tap.
- 20) Re-fit the 2 X screws 87 holding the rod end bracket in place (use a small amount of loctite on threads).
- 21) Apply grease to all the 4 grease nipples/Zerc fittings.
- 22) Check for free movement up and down and port and starboard. Adjust and rectify as necessary. Check for oil leaks and ensure drain and filler plugs are correctly tightened.

All loctited surfaces must be fully degreased with a solvent cleaner. (Automotive brake cleaner spray is a most useful product for this purpose)

SINGLE AUTOLOCK INTRODUCED 1990
 DOUBLE AUTOLOCK INTRODUCED 1994
 LUBRICATE WITH MEDIUM UNDERWATER GREASE.
 APPLY WITH A BRUSH EVERY MONTH (NO COPPER SLIP)

7.3 / 185 mm REF

DOW CORNING
 OR SIMILAR
 RUBBER SOLUTION

MOUNTING
 FACE 7° ONLY

MORSE 33C
 CABLE LENGTH
 TO BE SPECIFIED
 MODIFY AS SHOWN

MORSE BRACKET
 215155

WOOD SUPPORT
 FOR BRACKET
 TO SUIT

TRANSOM
 MOUNTING

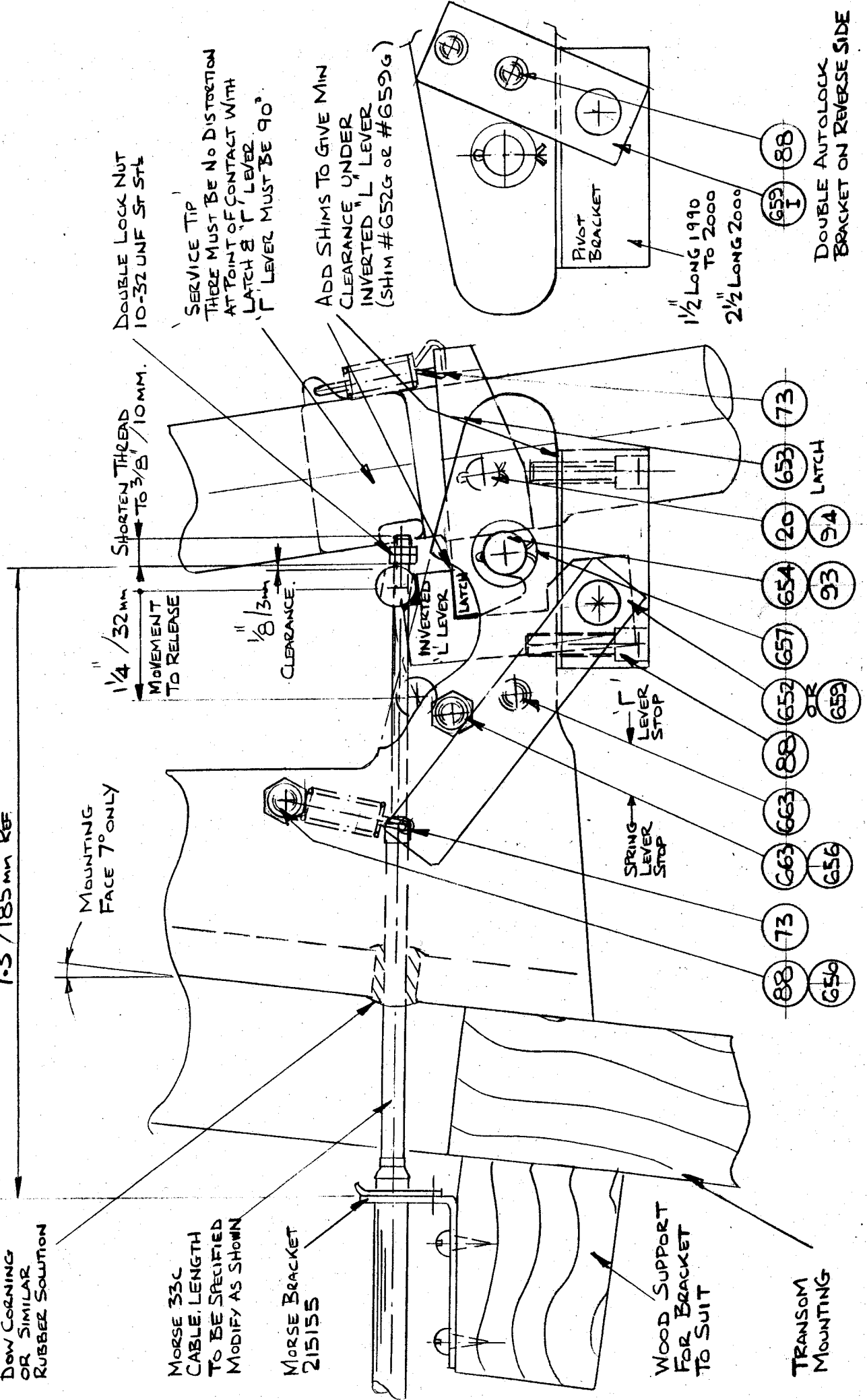

DOUBLE LOCK NUT
 10-32 UNF ST STL

SERVICE TIP
 THERE MUST BE NO DISTORTION
 AT POINT OF CONTACT WITH
 LATCH & 'L' LEVER.
 'L' LEVER MUST BE 90°

ADD SHIMS TO GIVE MIN
 CLEARANCE UNDER
 INVERTED 'L' LEVER
 (SHIM # 652G OR # 659G)

PIVOT
 BRACKET

1 1/2" LONG 1990
 TO 2000
 2 1/2" LONG 2000

659 I 88

DOUBLE AUTOLOCK
 BRACKET ON REVERSE SIDE

1/4" / 32mm
 MOVEMENT
 TO RELEASE
 SHORTEN THREAD
 TO 3/8" / 10MM.

1/8" / 3mm
 CLEARANCE.

INVERTED
 'L' LEVER
 LATCH

'L'
 LEVER
 STOP

SPRING
 LEVER
 STOP

88 73

659 I 88

20 654

657 652

88 663

663 652

88 663

663 652

88 73

659 656

88 73

659 656

88 73

659 656

88 73

659 656

88 73

659 656

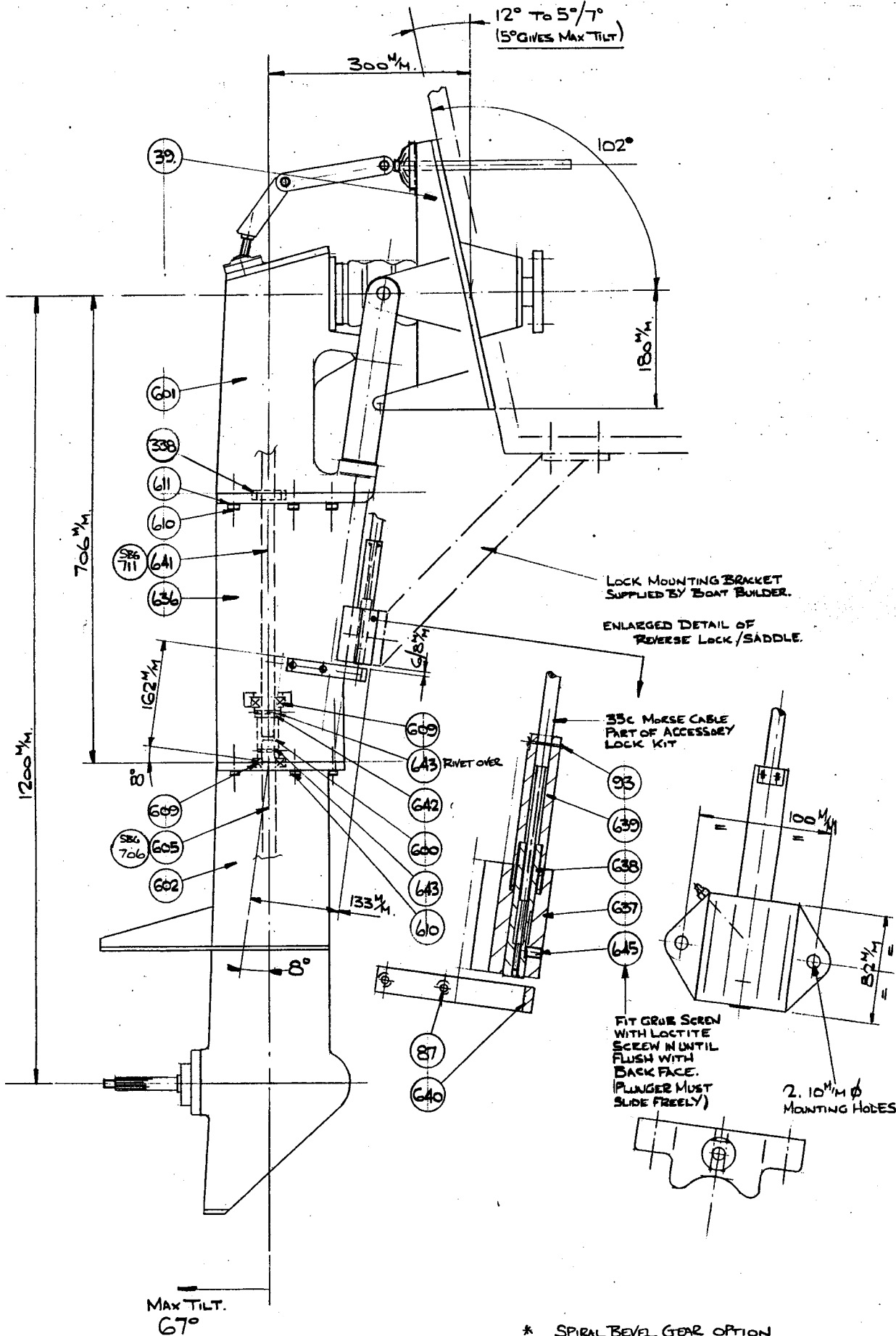

SILLETTE SONIC LTD. (C) A.R. PLANT FEB 98.

- * SPIRAL BEVEL GEAR OPTION NOTED AS SBG WITH N^o
- * TYPE 2 CATAMARAN DRIVE ADDITIONAL ITEMS FOR 1.2MTR.
- * ALL DETAIL & SPECIFICATION SUBJECT TO ALTERATION WITHOUT PRIOR NOTICE.

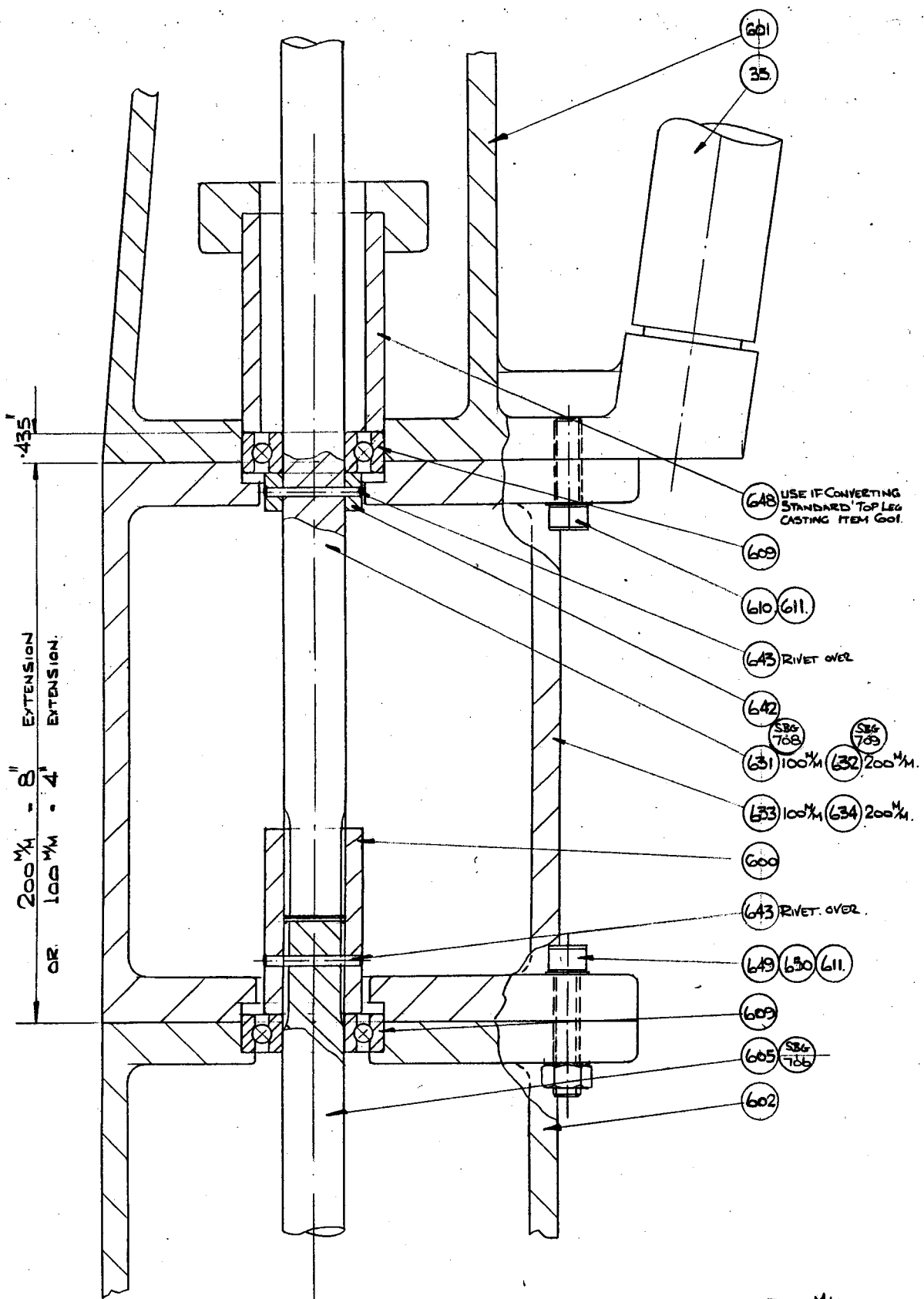

EXTENSION DETAIL FOR 900^{MM} TO 6096 AND 1000^{MM}. TYPE 2 CAT DRIVE.

SPRAL BEVEL GEAR OPTION SHOWN AS SBG WITH N2 ALL DETAIL & SPECIFICATION SUBJECT TO ALTERATION OR MODIFICATION WITHOUT PRIOR NOTICE.

SILLETTE SONIC LTD © A.R. PLANT FEB 98.