

**Auxiliary Propulsion Systems for Competition & Racing Sailboats, where minimum drag is the important factor. Also suitable for Cruising Sailboats, including Trimarans and Catamarans.**

## HYDRODRIVE MAXI II

Auxiliary propulsion for racing sailboats up to 27 mtrs/90 ft l.o.a.  
For use with diesel engines up to 150HP/112kw.

Available in 2 different underwater lengths, the longest having facility for water intake if required. Choose between LM6 Aluminium or Gunmetal bronze underwater section.

This model has been fitted to the following Racing Sailboats:

**FALCON**      **SAGAMORE**      **BLUE YANKEE**      **LA POSTE**  
**SAYONARA**    **BOOMERANG**    **N.Z. ENDEAVOUR**    **MERIT CUP**

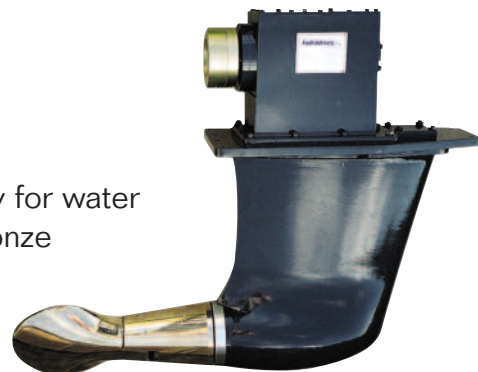

## HYDRODRIVE 80

Auxiliary propulsion for Racing and Cruising Sailboats up to 18 mtrs/60 ft l.o.a. For use with diesel engines up to 90HP/67kw.

Available with High or Low upper Gearbox height.  
LM6 Aluminium or Gunmetal Bronze underwater sections, which can be manufactured to include water intake facility, if required per the illustration

This model has been fitted to **CRACKLIN' ROSIE** and **PYEWACKET** and is specified by leading Racing Sailboat Designers.

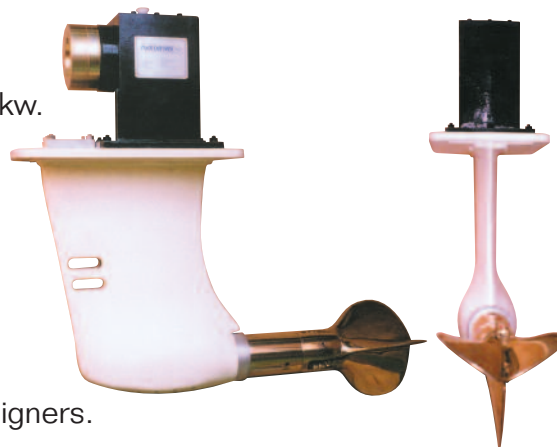

## HYDRODRIVE 3/4/1 TON

Auxiliary propulsion for Racing and Cruising Sailboats up to 18 mtrs/60 ft l.o.a. including Trimarans & Catamarans.  
For use with diesel engines up to 40HP/30kw.

Available with 3 different upper Gearbox heights and 2 different underwater lengths. Choose between LM6 Aluminium or Gunmetal Bronze underwater section.

*The illustration shows the shortest unit available.*

This model first introduced in 1990 has been fitted to the following sailboats

**TEAM GROUP FOUR**      **REGION HAUTE NORMANDIE**      **JUNO**  
**RUBIN**      **KINGFISHER**      **SPIRIT OF CANADA**      **CORUM**

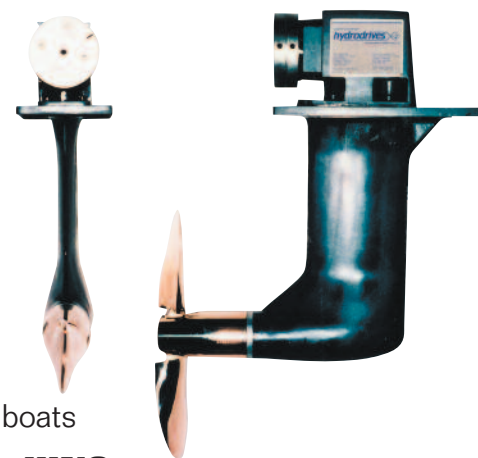

## STRUT DRIVES

### Sillette-Sonic Ltd

Sales & Correspondence  
Unit 2 Beverley Trading Estate  
190/192 Garth Road, Morden  
Surrey SM4 4LU - UK

tel: +44 (0)20 8337 7543  
fax: +44 (0)20 8330 9014  
e-mail: sales@sillette.co.uk  
website: <http://www.sillette.co.uk>

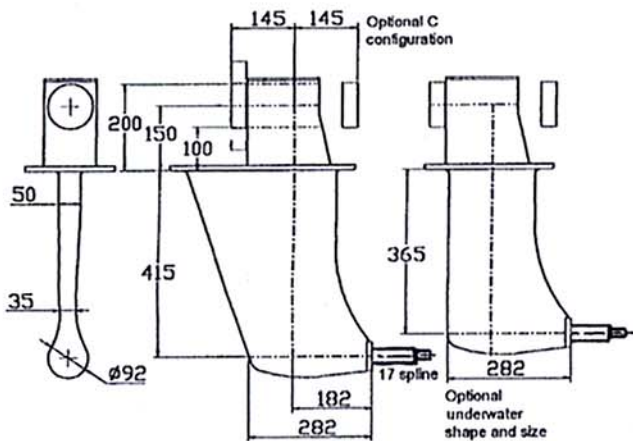
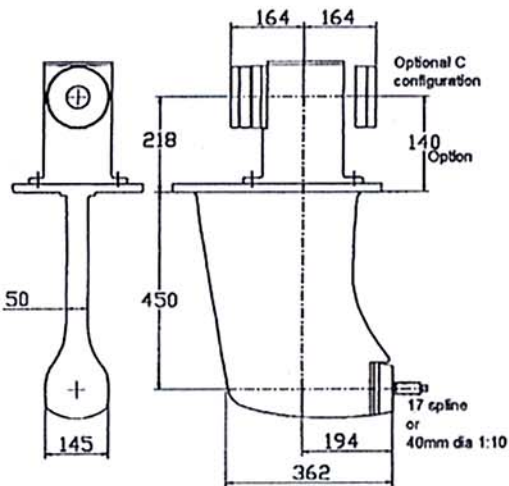
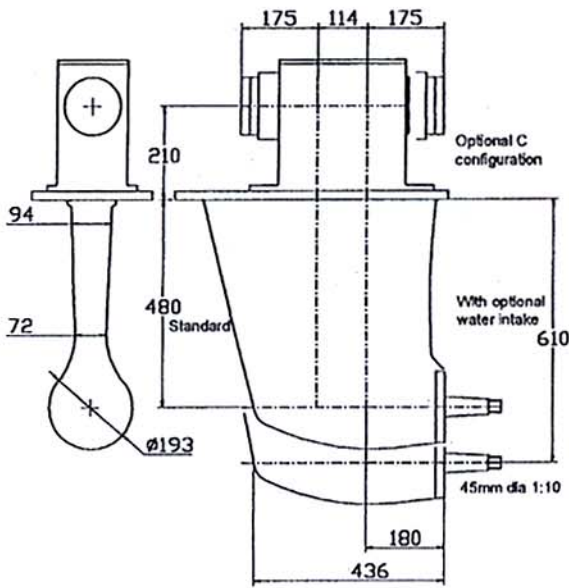

### HYDRODRIVE MAXI II

For IMS, 70 ft Whitbread Maxi etc.

Max input torque 85kg/mtr  
Designed for use with GORI  
2 blade race type folding propeller  
680 Dia. or (750 Dia Special)  
GORI, 3 blade folding 24" dia.

Can accept, Aquadrive, R & D,  
Vetus and Layrub couplings

Typical engines used VOLVO TAMD31A, TAMD41H  
YANMAR 4LH-HTE, 130/140 HP.4JH3-DTE. 125HP  
YANMAR 4J 4HTE. 4BY150  
VOLVO D3-110, D3-110, D3-160  
LOMBARDINI LDW 194JMT  
with 2, 2.5 or 3:1 Gearbox fitted

Price basic unit, all aluminium  
Plus 2 Blade Gori  
or Plus 3 Blade Gori  
Extra for 610mm lower unit  
Extra for Bronze lower unit  
Option for 490 mm slimline

£20,000  
£19,180  
£1,800  
£3,050

### HYDRODRIVE 80

For 2 ton, 50 foot, 60 foot etc.

Max input torque 45 kg/mtr.  
Designed for use with GORI folding  
race propeller 475 or 530 diameter  
or GORI 3 blade folding propeller  
20" or 18" diameter.

Can accept, Aquadrive, R & D,  
Vetus or Layrub couplings.

Typical engines used, YANMAR  
4JH3-E, 4JH3-TE, 4JH4E  
VOLVO D2-75 & D2-55  
LOMBARDINI LDW 2204M  
4JH4-TE Reduction  
box 3:1, 2.6:1 and 2:1, to maximise  
torque utilisation.

Price basic unit all aluminium  
without propeller  
extra for bronze lower  
with hydraulic motor mounting

£6,700  
£1,370  
£5,200

### HYDRODRIVE 3/4 / 1 TON

Fitted to many Admirals cup winners.

Max input torque 22 kg/mtr  
Designed for use with GORI,  
2 blade folding race propeller  
380 & 425 mm diameter.

Can accept Aquadrive or  
Metalastic couplings.

Typical engines used YANMAR 3GM30, 3YM30  
VOLVO 2030, YANMAR 3JH3, BUKH DV36, VOLVO D1-30  
LOMBARDINI LDW 1404M  
ie 25 - 40HP with 2.6:1 or 2:1 ratio

Price basic unit all aluminium  
without propeller  
with bronze lower  
for use with electric motor  
reversed rotation extra

£3,100  
£3,650  
£2,300  
£190